

PARTS MANUAL

Texas 120-39 1995

Model F3554-230



12HP/39" Deck

HOW TO ORDER REPAIR PARTS

Only use a factory repair part. Repair parts, except for the engine or the transmission, are available from the store where the unit was purchased, a service shop recommended by the store, or an authorized service shop found in the yellow pages of the telephone directory.

If you cannot get a repair part or service as described above, call or write to the Central Parts Distributor shown on the back page of this manual or write: **Customer Service Department, Outdoor Power Equipment, PO Box 8000, Jackson, TN 38308, 1-800-247-7464.** Collect telephone calls will not be accepted. When you order, include the following information: 1- Complete Model Number (see nameplate), 2- Date of Manufacture, 3- Complete Part Number, 4- Description, and (5) Quantity.

Repair parts for the engine or the transmission are available from the manufacturer's authorized service center found in the yellow pages of the telephone directory. See the individual engine or transmission warranties.

- Read and keep this parts list book for future reference.
- This parts list book contains drawings and part numbers necessary to obtain repair parts.
- Record the following information about your unit. This information is necessary when ordering parts or in case of loss or theft.

WHERE PURCHASED: _____

DATE PURCHASED: Month _____ Day _____ Year _____

MODEL NO.: _____ DATE OF MANUFACTURE: _____

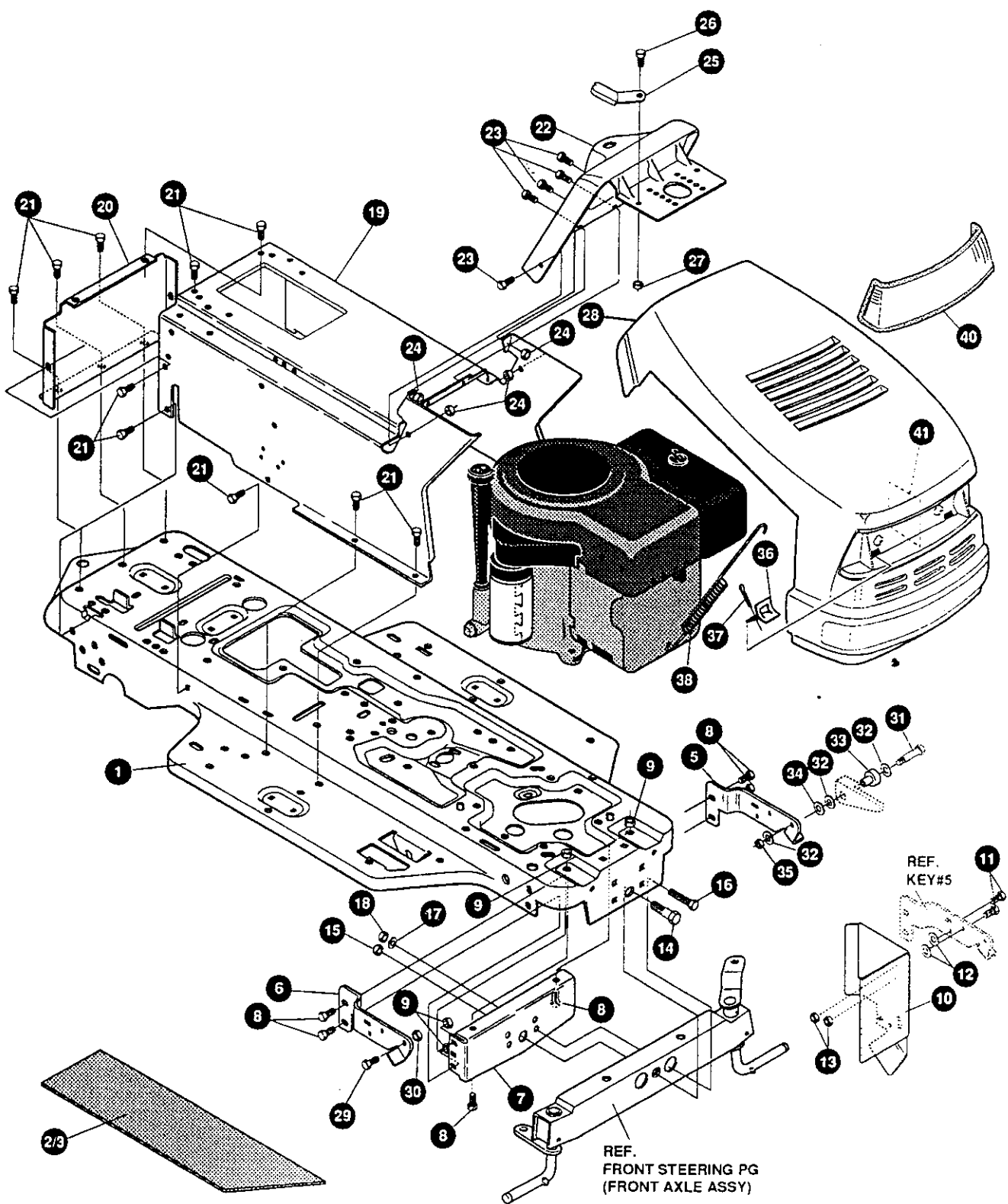

REF.
FRONT STEERING PG
(FRONT AXLE ASSY)

REF.
KEY#5

NOTE: ALWAYS USE ORIGINAL EQUIPMENT PARTS.
Use of service/replacement parts other than original equipment parts may void your warranty.

**ALL UNNUMBERED
ITEMS ARE INTERCHANGEABLE
WITH OPPOSITE SIDE**

335395 A

KEY#	PART#	DESCRIPTION	QTY
1	331173-889	FRAME, MAIN, SF, RIDER	1
2	331834	FOOT PAD, RH, SF, FULL WIDTH	1
3	331835	FOOT PAD, LH, SF, FULL WIDTH	1
5	313001-853	BRACKET, GRILLE SUPPORT, LH	1
6	313002-853	BRACKET, GRILLE, RH	1
7	56362-853	BRACKET, SUPPORT, FRONT AXLE-SF	1
8	328154	SCREW, 5/16-18 X 1.0 WDFLLK	6
9	55273	NUT, 5/16-18 WDFLLKLRG WHIZ	6
10	312908-853	SHIELD, HEAT, 11&12HP, B&S & TEC, SF	1
11	180020	SCREW, 1/4-20 X .75 HHC	2
12	311245	WASHER, FLAT.250 X .75 X INSULATE	2
13	1502	NUT, 1/4-20 REGHEXCTRLK	2
14	29616	BOLT, .625 X 1.890 HSH, 1/2-20	1
15	274654	NUT, 1/2-20 REGHXCTRLK	1
16	180138	SCREW, 3/8-16 X 3.00 HHC	2
17	2483	WASHER, .39 ID X 1.25 D X .07 BELLVIL	2
18	1499	NUT, 3/8-16 REGHXCTRLK	2
19	324748-889	CONSOLE, SF, FENDER SHIFT	1
20	56235-889	CONSOLE, REAR COVER	1
21	995346	SCREW, 1/4-20 X .50 WAHHTAP	15
22	320466-830	DASH, SF	1
23	44811	SCREW, 1/4-20 X .75 WAHHTAP	6
24	50352	NUT, 1/4-20 WDFLLK TOPLOCK	4
25	313021-853	GUIDE, HOOD SF & LF, H13, H14, H15	2
26	180020	SCREW, 1/4-20 X .75 HHC	2
27	51335	NUT, 1/4-20 WDFLWHIZ-LK	2
28	335409	HOOD, SMALL, H-13	1
29	56676	BOLT, .375 X .580 HSH, 5/16-18	1
30	1498	NUT, 5/16-18 REGHEXCTRLK	1
31	180042	SCREW, 1/4-20 X 1.75 HHC	1
32	120392	WASHER, FLAT .281 X .63 X .065	3
33	309532	BEARING, FLANGED, PLASTIC HOOD	1
34	311245	WASHER, FLAT.250 X .75 X INSULATE	1
35	1502	NUT, 1/4-20 REGHEXCTRLK	1
36	310801	ANCHOR, HOODLANYARD	1
37	121222	PIN, COTTER .090 DIA X .75 LONG	1
38	304784	SPRING, HOOD LATCH	1
40	302670	LENS, HEADLAMP, HOODS	1
41	301452	FOIL, HEAT REFLECTOR	1
	330641	PARTS MANUAL	1
	336407	OPERATOR'S MANUAL (DANISH)	1



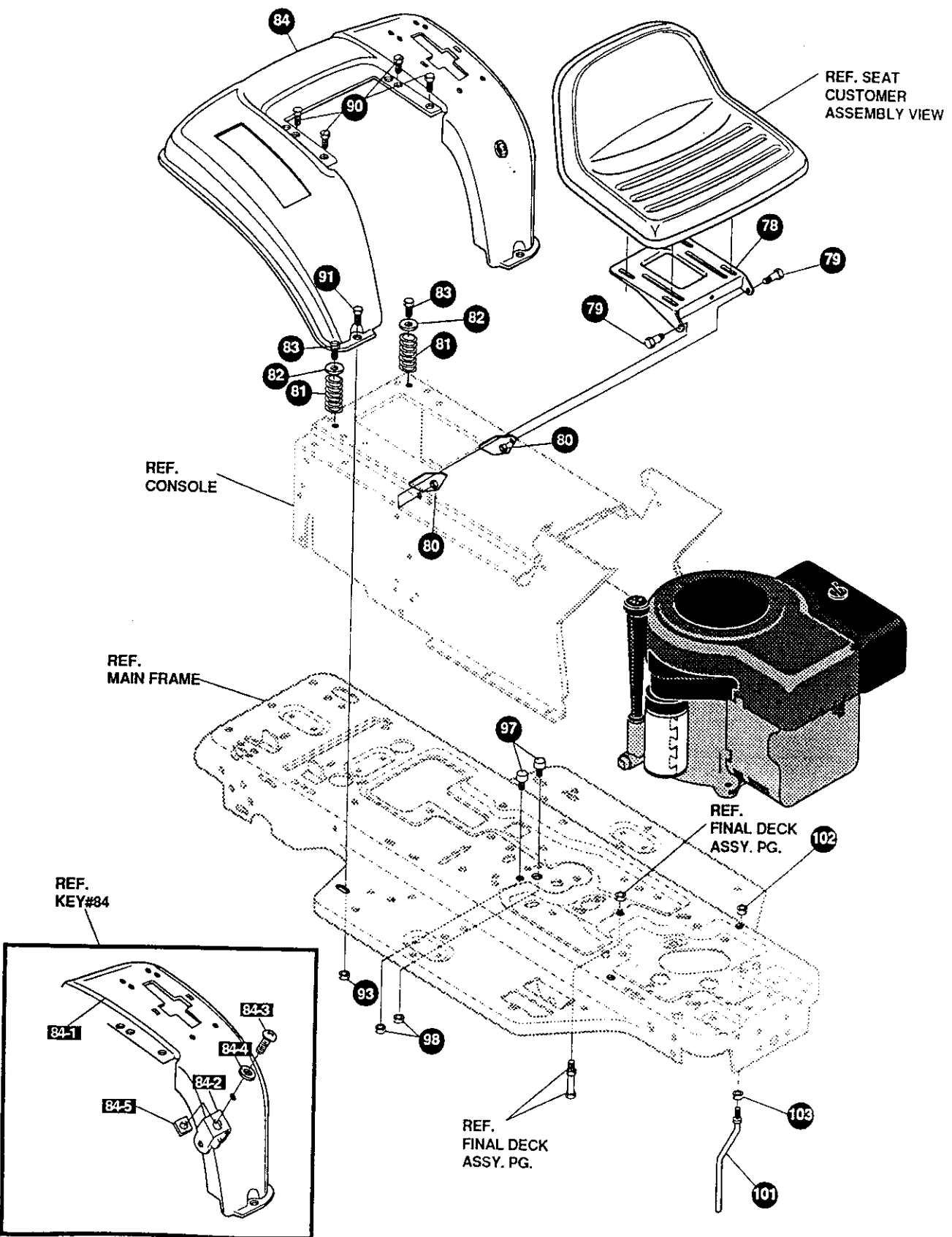

NOTE: ALWAYS USE ORIGINAL EQUIPMENT PARTS.
Use of service/replacement parts other than original equipment parts may void your warranty.

**ALL UNNUMBERED
ITEMS ARE INTERCHANGEABLE
WITH OPPOSITE SIDE**

335395 A

KEY#	PART#	DESCRIPTION	QTY
78	58367-889	PLATE, SEAT, F5, SF, LF	1
79	20507	BOLT, .437 X .156 HHSH, 5/16-18	2
80	1498	NUT, 5/16-18 REGHEXCTRLK	2
81	330463	SPRING, SEAT 1.50 OD X 2.25 LONG	2
82	120392	WASHER, FLAT .281 X .63 X .065	2
83	995346	SCREW, 1/4-20 X .50 WAHTAP	2
84	*	ASSEMBLY, FENDER, F-5, SF, SOF/LOF	1
84-1	332423-889	FENDER, F-5, SF, S.O.F/L.O.F.	1
84-2	9239	CLEVIS	1
84-3	439455	SCREW, 5/16-18 X .56 PHPNMA	1
84-4	301551	WASHER, .344 ID X 1.50 D X .09	1
84-5	120373	NUT, 5/16-18 SQUARE	1
90	995346	SCREW, 1/4-20 X .50 WAHTAP	4
91	126358	BOLT, 5/16-18 X 1.00 CARRLN	2
93	55273	NUT, 5/16-18 WDFLLKLRG, WHIZ	2
97	53446	PIN, 5/16-18, HOOD LATCH	2
98	271184	NUT, 5/16-18 HEXKEPS	2
101	50653	GUIDE, BELT	1
102	41529	NUT, 3/8-16 HXCTRLKJAM	1
103	271190	NUT, 3/8-16 HEXKEPS	1

* ORDER INDIVIDUAL PARTS

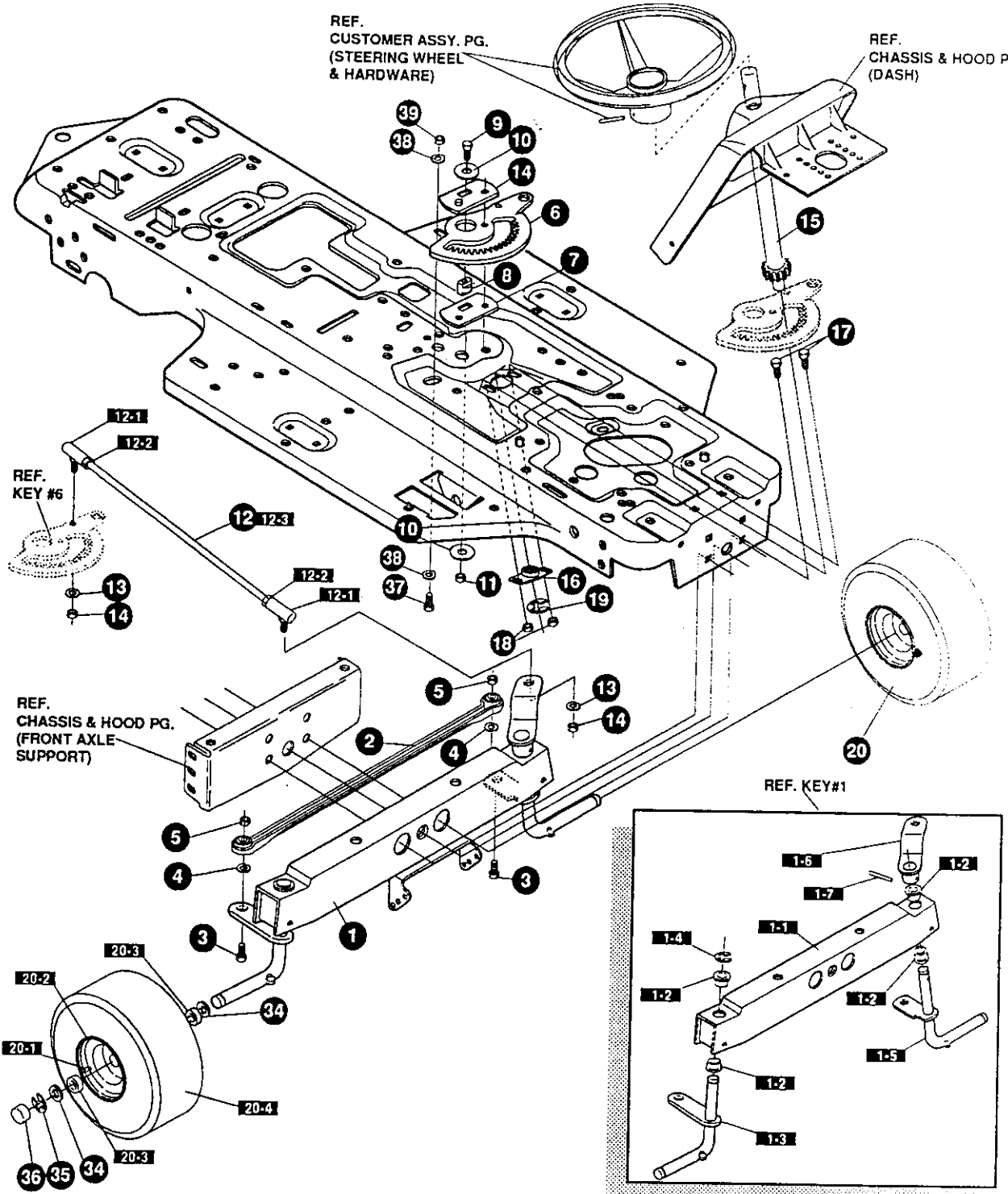

NOTE: ALWAYS USE ORIGINAL EQUIPMENT PARTS.
 Use of service/replacement parts other than original equipment parts may void your warranty.

ALL UNNUMBERED ITEMS ARE INTERCHANGEABLE WITH OPPOSITE SIDE

324972 H

KEY#	PART#	DESCRIPTION	QTY
1	*	AXLE, FRONT ASSEMBLY, SF, LONG	1
1-1	324915	ASSEMBLY, FRONT AXLE, SF, GS	1
1-2	50546	BEARING, FLANGE .759 ID X 1.002 OD X .75	4
1-3	310368	SPINDLE, ASSEMBLY, RH, LONG, SF	1
1-4	36625	RING, RETEX .57 X .05 TRU 5133-75	1
1-5	310367	SPINDLE, ASSEMBLY, LH, LONG, SF	1
1-6	327619	ARM ASSEMBLY, SF, 4WS, FRONT STEERING	1
1-7	454565	PIN, SPRING .250 DIA X 1.25 LONG	1
2	302688	ASSEMBLY, TIE ROD, 19.31 LONG	1
3	180124	SCREW, 3/8-16 X 1.25 HHC	2
4	120382	WASHER, REGSPTLK .393 X .68 X .10	2
5	1499	NUT, 3/8-16 REGHXCTRLK	2
6	327399	GEAR, SECTOR, SF, 2WS	1
7	333289	PLATE SECTOR, SF, 4WS, BLACK	2
8	330021	BUSHING, SECTOR, GEAR, SF, 4WS	1
9	181643	SCREW, 3/8-24 X 1.50 HHC	1
10	845	WASHER, FLAT .390 X 1.25 X .119	2
11	412349	NUT, 3/8-24 HXCTRLK	1
12	328808	DRAG LINK ASSEMBLY, 17.69 LONG	1
12-1	57158	BALL JOINT, 3/8 THD, SHORT STUD	2
12-2	124925	NUT, 3/8-24 REGHEXJAM	2
12-3	56190	DRAG LINK	1
13	120382	WASHER, REGSPTLK .393 X .68 X .10	2
14	120369	NUT, 3/8-24 REGHEX	2
15	327834	SHAFT, PIN-STEER, BLACK	1
16	325692	BEARING, FLANGE .50 ID X 1.370 OD	1
17	326505	SCREW, 1/4-20 X .75 (TQ 30-35 FT#)	2
18	46931	NUT, 1/4-20 WDFL MAC-LOCK	2
19	20864	RING, RET E .39 X .04 TRU 5133-50	1
20	*	TIRE & RIM, PU 15 X 6.0 X 6	2
20-1	24167	VALVE STEM	
20-2	39829	RIM, WHEEL	
20-3	314416	BEARING, FLANGE	
20-4	TIRE	REFER TO TIRE TREAD PAGE	
34	642	WASHER, FLAT .755 X 1.31 X .075	4
35	36625	RING, RETEX .57 X .05 TRU 5133-75	2
36	40394	HUB CAP, 1.500 ID X 7/8 LONG	2
37	180124	SCREW, 3/8-16 X 1.25 HHC	1
38	120394	WASHER, FLAT .406 X .81 X .065	2
39	45171	NUT, 3/8-16 HWDFL WHIZ-LOCK	1

* ORDER INDIVIDUAL PARTS

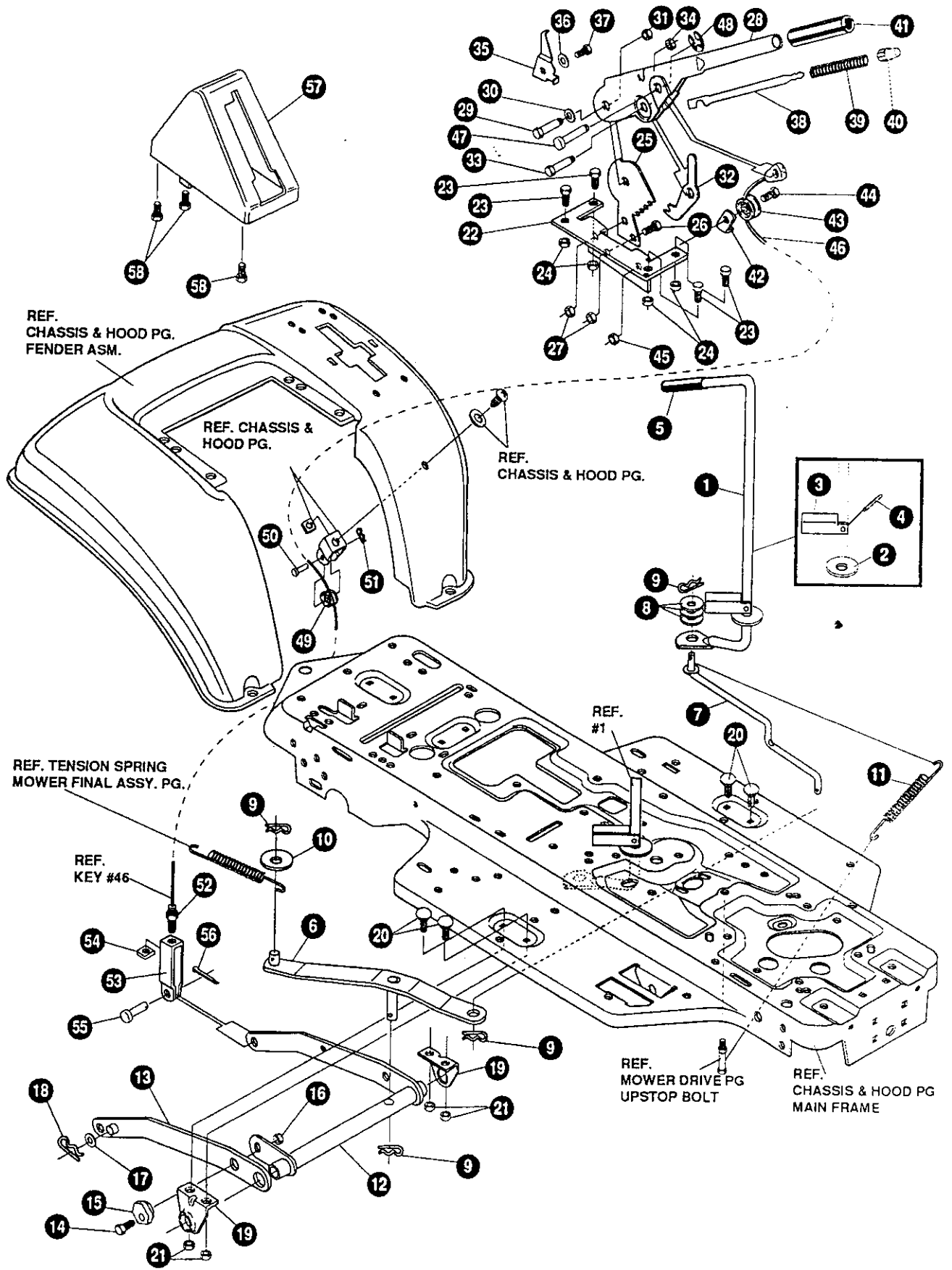

NOTE: ALWAYS USE ORIGINAL EQUIPMENT PARTS.
 Use of service/replacement parts other than original equipment parts may void your warranty.

ALL UNNUMBERED ITEMS ARE INTERCHANGEABLE WITH OPPOSITE SIDE

331232 C

KEY#	PART#	DESCRIPTION	QTY
1	325591	LEVER, CLUTCH, RH, PTO	1
2	22265	WASHER, FLAT .515 X 1.38 X .119	1
3	305225	STOP, PTO ENGAGE	1
4	326386	PIN, SPRING.187 DIA X 1.13 LONG	1
5	331624	KNOB, ROUND 1.50 DIA OR GRIP, SF	1
6	325587	STRAP ASSEMBLY, PTO BELCRANK, SF	1
7	325590	ROD, BELCRANK LINK, SF	1
8	274517	WASHER, FLAT .406 X .73 X .063	3
9	8260	PIN, HAIR .091 DIA X 1.66 LONG	4
10	25210	WASHER, FLAT .386 X 1.25 X .09	1
11	325802	SPRING, .69 X 7.75 X .0897 TENSION	1
12	326114-853	LIFT ASSEMBLY, LH	1
13	325130-853	LIFT ASSEMBLY, RH, SF	1
14	180079	SCREW, 5/16-18 X 1 .00 HHC	1
15	58247	NUT, ADJUST	1
16	1498	NUT, 5/16-18 REGHEXCTRLK	1
17	417098	WASHER, FLAT .531 X 1.06 X .063	2
18	8260	PIN, HAIR .091 DIA X 1.66 LONG	2
19	325495-853	BRACKET, REAR HANG, SUSP	2
20	330967	BOLT, 5/16-18 X 1.00 CARR	4
21	1498	NUT, 5/16-18 REGHEXCTRLK	4
22	313926	BRACKET, HEIGHT/ADJUST SUPPORT	1
23	180077	SCREW, 5/16-18 X .75 HHC	4
24	1498	NUT, 5/16-18 REGHEXCTRLK	4
25	301238	QUADRANT, HEIGHT ADJUST	1
26	180077	SCREW, 5/16-18 X .75 HHC	2
27	1498	NUT, 5/16-18 REGHEXCTRLK	2
28	322292-853	HANDLE,LIFT SHORT(30" S.F.)	1
29	300171	BOLT, .500 X .270 HHSH, 5/16-18	1
30	996418	WASHER, FLAT .506 X .75 X .024	1
31	44108	NUT, 5/16-18 HWDFLCTRLK	1
32	301239	PAWL, SQUARE	1
33	300171	BOLT, .500 X .270 HHSH, 5/16-18	1
34	44108	NUT, 5/16-18 HWDFLCTRLK	1
35	9435	POINTER, HEIGHT ADJUST	1
36	138479	WASHER, EXLK .195 X .41 X .03	1
37	35287	SCREW, #8-32 X .38 HHWATAP	1
38	303027	ROD, ACTUATOR-SHORT	1
39	58326	SPRING, HEIGHT ADJUST	1
40	58325	KNOB, HEIGHT ADJUST PUSH BUTTON	1
41	58329	GRIP, .750 OD W/ HOLE BLACK	1
42	9149	BRACKET, CABLE RETAINER	1
43	48306	PULLEY, POWDER METAL	1
44	58336	BOLT, .375 X .375 HHSH, 1/4-20	1
45	1502	NUT, 1/4-20 REGHEXCTRLK	1
46	57511	LIFT CABLE, 20.75 LONG	1
47	300310	PIN, CLEVIS .310 DIA+.475 LONG	1
48	300311	RING, RET E .31 X .25 TRU 5133-31	1
49	48306	PULLEY, POWDER METAL	1
50	300317	PIN, CLEVIS .375 DIA X .81 LONG	1
51	8260	PIN, HAIR .091 DIA X 1.66 LONG	1
52	120375	NUT, 1/4-20 REGHEX	1
53	9405	CLEVIS, LIFT CABLE	1
54	120372	NUT, 1/4-20 REGSQ	1
55	39522	PIN, CLEVIS .312 X .812	1
56	121222	PIN, COTTER .090 DIA X .75 LONG	1
57	333903	LIFT COVER, F5, LF, SF, BLACK	1
58	300340	SCREW, #10 X .75 HHPLAST, BLACK	3

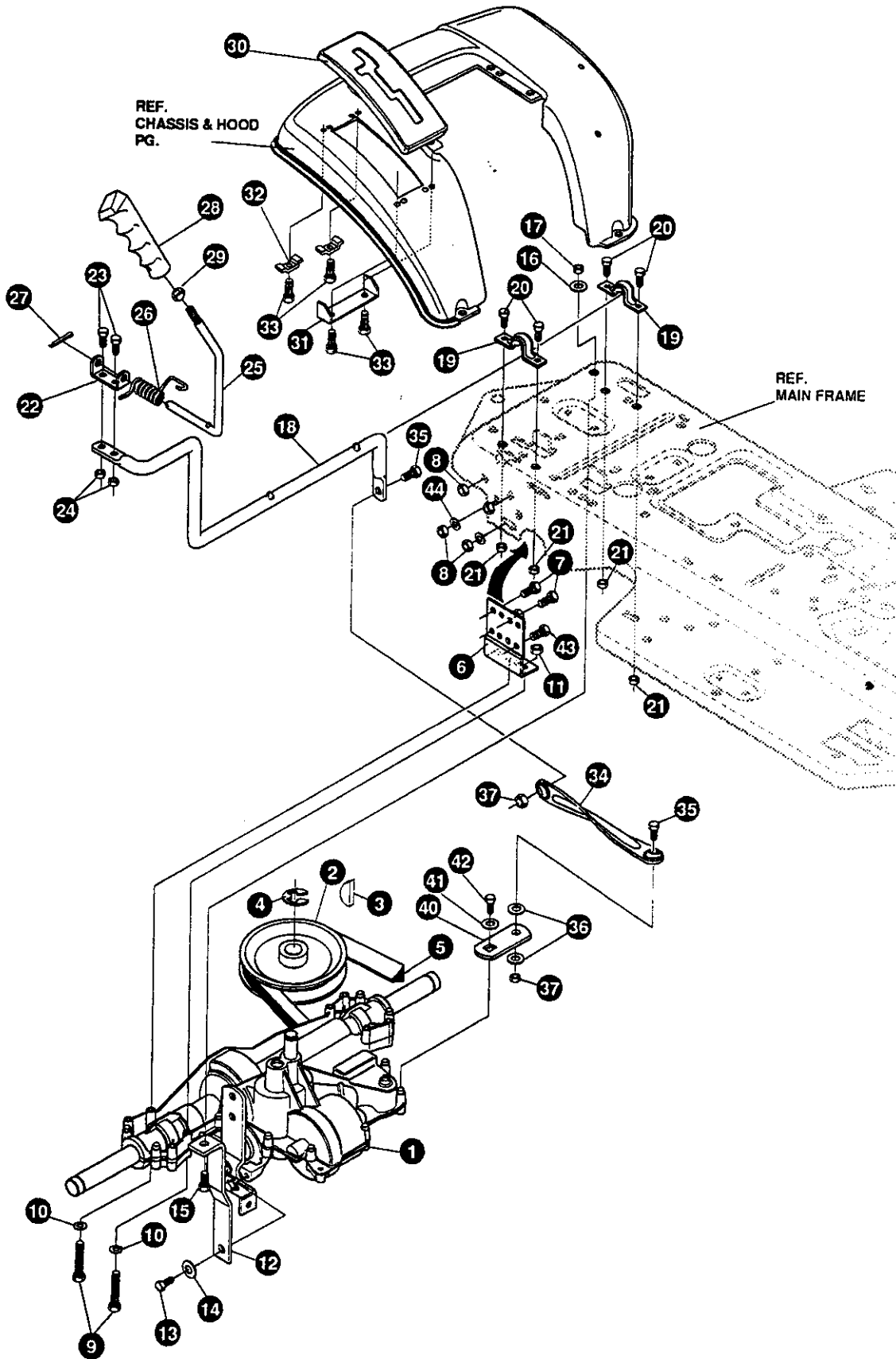

NOTE: ALWAYS USE ORIGINAL EQUIPMENT PARTS.
 Use of service/replacement parts other than original
 equipment parts may void your warranty.

**ALL UNNUMBERED
 ITEMS ARE INTERCHANGEABLE
 WITH OPPOSITE SIDE**

335103 A

KEY#	PART#	DESCRIPTION	QTY
1	^	TRANSAXLE, PEERLESS, 930-5, LF/SF	1
2	303109	PULLEY, 6.6 OD, V4L, T/A	1
3	50795	KEY, HI-PRO 606, .75 DIA X .187 WD	1
4	22053	RING, RETEX .58 X .035 TRU 5100-62	1
5	54758	BELT, V 4L, 82.00, SF, DRIVE	1
6	326615-853	BRACKET, TRANSAXLE	2
7	180077	SCREW, 5/16-18 X .75 HHC	4
8	1498	NUT, 5/16-18 REGHEXCTRLK	8
9	180091	SCREW, 5/16-18 X 2.50 HHC	4
10	120393	WASHER, FLAT .344X .69 X .065	4
11	1498	NUT, 5/16-18 REGHEXCTRLK	4
12	323126	BRACKET, STABILIZER, BLACK	1
13	35498	SCREW, 5/16-18 X .75 WAHTAP	1
14	120638	WASHER, HVSP TLK .328 X .60 X .09	1
15	180079	SCREW, 5/16-18 X 1.00 HHC	1
16	138485	WASHER, EXLK .320 X .61 X .03	1
17	1498	NUT, 5/16-18 REGHEXCTRLK	1
18	319113	LEVER, SHIFT LOWER, SF, FENDER SHIFT	1
19	302760	CLAMP .625 DIA	2
20	180077	SCREW, 5/16-18 X .75 HHC	4
21	1498	NUT, 5/16-18 REGHEXCTRLK	4
22	310356	BRACKET, PIVOT, SHIFT LEVER	1
23	180020	SCREW, 1/4-20 X .75 HHC	2
24	1502	NUT, 1/4-20 REGHEXCTRLK	2
25	324798	LEVER, SHIFT, UPPER, SOF, 1/2-13	1
26	310265	SPRING, TORSION .56 X .95 X .095	1
27	137185	PIN, COTTER .125 DIA X 1.00 LONG	1
28	306690	KNOB, ROUND 1.50 DIA OR GRIP, SF	1
29	120238	NUT, 1/2-13 HEXJAM	1
30	311209	COVER, PLASTIC, LF, P930/F4360-6	1
31	311257-853	BRACKET COVER F-5, FENDER SHIFT	1
32	1341	CLAMP, SPRING 1.17" ID	2
33	311331	SCREW, 1/4-15 X .44/53 HILOHWA	4
34	309546	LINK, TIE ROD, SHIFT, 7.812	1
35	180124	SCREW, 3/8-16 X 1.25 HHC	2
36	120394	WASHER, FLAT .406 X .81 X .065	2
37	1499	NUT, 3/8-16 REGHXCTRLK	2
40	309637	BRACKET, SHIFT, 5SP, SF	1
41	57157	WASHER, .750 X .250 SP-TRANSAXLE	1
42	56255	SCREW, 1/4-28 X .75 NYLHHC	1
43	327917	SCREW, 5/16-18 X 1.50HHCFT	4
44	73787	WASHER, FLAT .330 X .75 X .1793	4

^ CONTACT YOUR NEAREST TRANSAXLE DEALER FOR PARTS & SERVICE

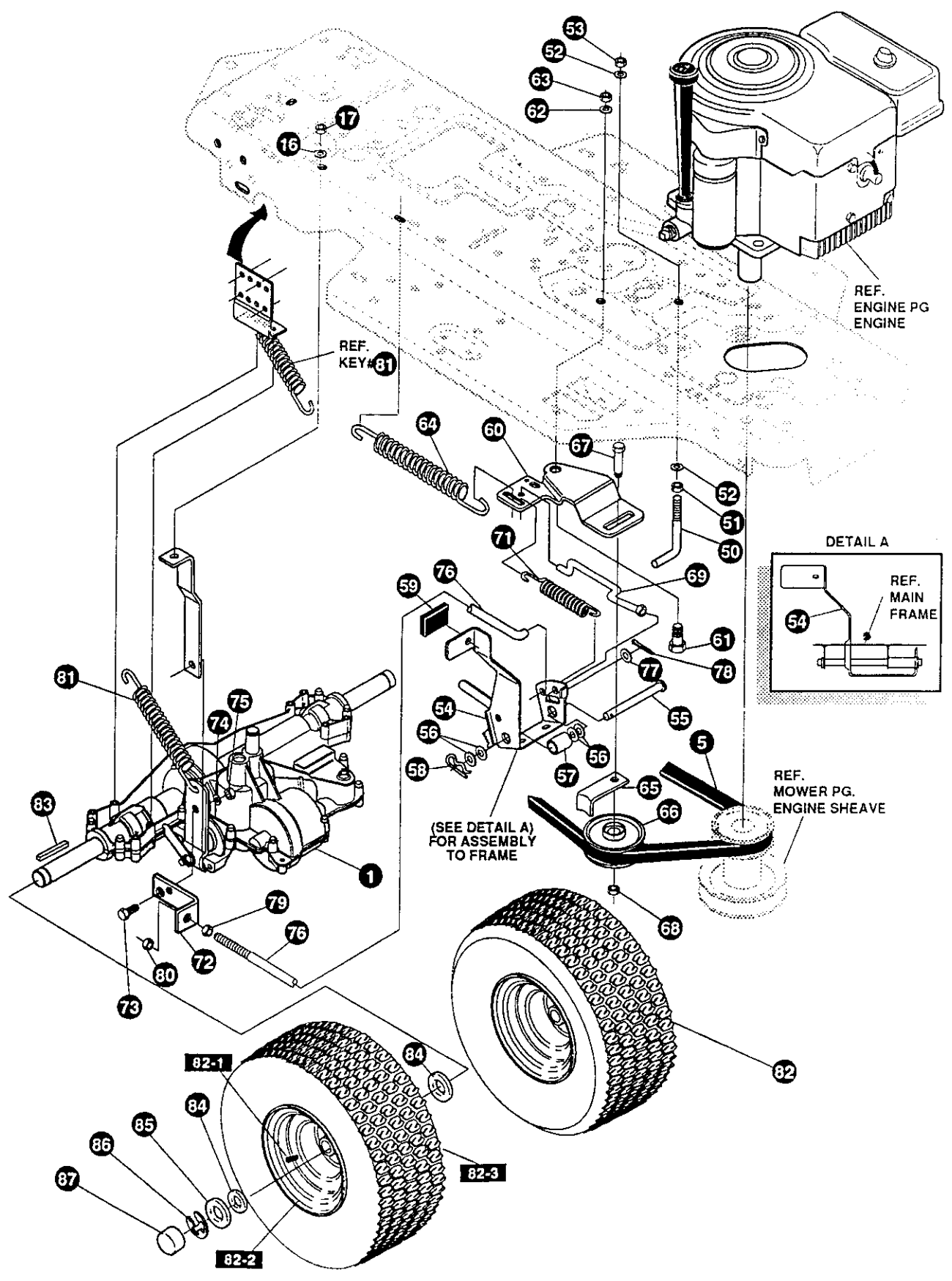

(SEE DETAIL A) FOR ASSEMBLY TO FRAME

NOTE: ALWAYS USE ORIGINAL EQUIPMENT PARTS. Use of service/replacement parts other than original equipment parts may void your warranty.

ALL UNNUMBERED ITEMS ARE INTERCHANGEABLE WITH OPPOSITE SIDE

335103 A

KEY#	PART#	DESCRIPTION	QTY
50	49896	BELT GUIDE	1
51	271184	NUT, 5/16-18 HEXKEPS	1
52	120393	WASHER, FLAT .344 X .69 X .065	2
53	1498	NUT, 5/16-18 REGHEXCTRLK	1
54	331836	ASSEMBLY, PEDAL, BRAKE, CLUTCH, SF	1
55	319676	PIN, CLEVIS .500 D X 4.87 LONG	1
56	2968	WASHER, FLAT .504 X .75 X .059	4
57	331972	SPACER, SLEEVE .53 X .62 X 1.240	1
58	56180	PIN, HAIR .091 DIA X 1.62 LONG	1
59	48761	PAD, CLUTCH/BRAKE PEDAL	1
60	321969	IDLER ARM BRACKET, TRACTION, SF	1
61	329989	BOLT, .625 X .135 HSSH, 5/16-18	1
62	45602	WASHER, FLAT .333 X .87 X .119	1
63	1498	NUT, 5/16-18 REGHEXCTRLK	1
64	327867	SPRING, 3/4 OD X 7.75 X .091 TENSION	1
65	39659	RETAINER, BELT	1
66	35374	PULLEY, IDLER V4L, 3.06 X .62	1
67	45892	BOLT, 3/8-16 X 1.50 CARRSN	1
68	1499	NUT, 3/8-16 REGHXCTRLK	1
69	333175	CLUTCH ROD ASSEMBLY, .268 DIA 3.92	1
71	326780	SPRING, 3/8 OD X 2.18 X .055 TENSION	1
72	323127	BRACKET, BRAKE ROD, BLACK	1
73	20507	BOLT, .437 X .156 HSSH, 5/16-18	1
74	4230	WASHER, FLAT .328 X .68 X .104	1
75	1498	NUT, 5/16-18 REGHEXCTRLK	1
76	323222	BRAKE ROD, RIDER, BLACK	1
77	120393	WASHER, FLAT .344 X .69 X .065	1
78	121222	PIN, COTTER .090 DIA X .75 LONG	1
79	271184	NUT, 5/16-18 HEXKEPS	1
80	44108	NUT, 5/16-18 HWDFLCTRLK	1
81	35410	SPRING, .071 X .62 X 4.37	1
82	*	TIRE & RIM, PU 18 X 8.5 X 8	2
82-1	24167	VALVE STEM	
82-2	326362	RIM, WHEEL	
82-3	TIRE	REFER TO TIRE TREAD PAGE	
83	52928	KEY, SQUARE .187 SQUARE X 2.25 LONG	2
84	642	WASHER, FLAT .755 X 1.31 X .075	4
85	42815	WASHER, FLAT .755 X 1.53 X .07	2
86	36625	RING, RETEX .57 X .05 TRU 5133-75	2
87	40394	HUB CAP, 1.500 ID X 7/8 LONG	2

* ORDER INDIVIDUAL PARTS

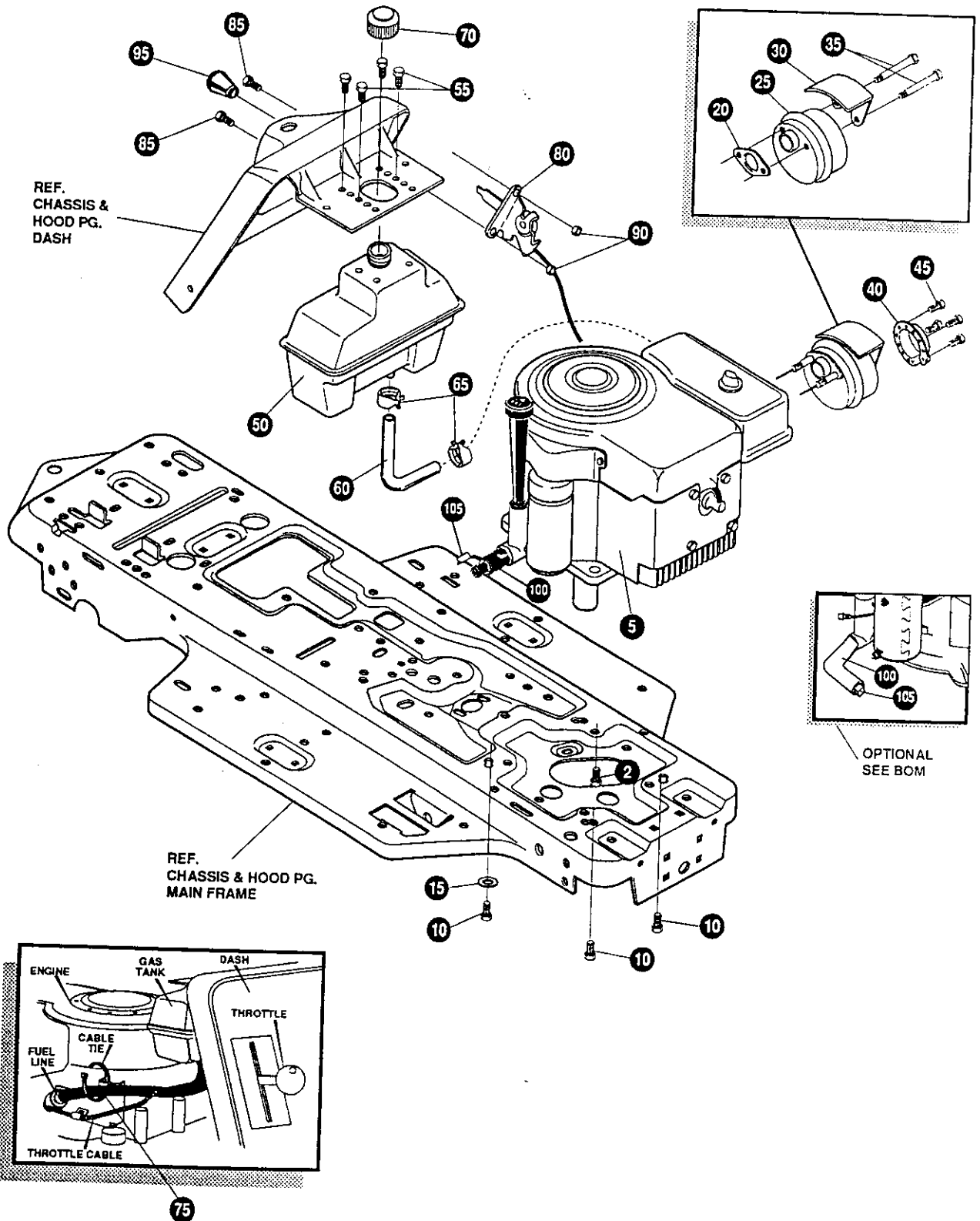

REF.
CHASSIS &
HOOD PG.
DASH

REF.
CHASSIS & HOOD PG.
MAIN FRAME

OPTIONAL
SEE BOM

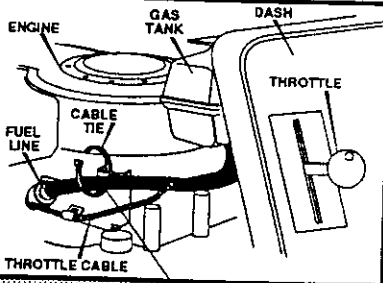

75

NOTE: ALWAYS USE ORIGINAL EQUIPMENT PARTS.
Use of service/replacement parts other than original
equipment parts may void your warranty.

**ALL UNNUMBERED
ITEMS ARE INTERCHANGEABLE
WITH OPPOSITE SIDE**

331639 B

KEY#	PART#	DESCRIPTION	QTY
5	*	ENGINE, 10-12HP, B&S, 3A	1
10	50947	SCREW, 3/8-16 X 1.25 WAHHTAP, BLACK	4
15	138489	WASHER, EXLK .384 X .69 X .04	1
20	46708	GASKET, MUFFLER	1
25	57908	MUFFLER-DOMESTIC/EXPORT ROUND	1
30	54767	SHIELD, HEAT, FOR ROUND MUFFLER	1
35	54980	SCREW, 5/16-18 X 3.50 HHC	2
40	56472	DEFLECTOR SIDE OUT (BS222573)	1
45	35287	SCREW, #8-32 X .38 HHWATAP	4
50	314989	TANK, FUEL, 1 GALLON, CLEAR	1
55	300303	SCREW, .25 X .75 X .51 HHWA, PLASTITE	4
60	42258	TUBING, .25 X .50 X BULK GAS LINE	12.0"
65	47345	CLAMP, HOSE SCREW TYPE	2
70	46704	CAP, GAS 1-1/2-7 THD, BLACK	1
75	57444	TIE, CABLE BLACK NYLON, 5.62 LONG	1
80	320031	THROTTLE CONTROL	1
85	274707	SCREW, 10-24 X .50 WAHHMA	2
90	308459	NUT, #10-24 HXHDNYLK	2
95	50607	KNOB, ROUND THROTTLE, BLACK	1
100	325547	OIL DRAIN VALVE OR TUBE	1
105	327422	CAP OR PLUG FOR OIL DRAIN	1

* SEE ENGINE MANUAL

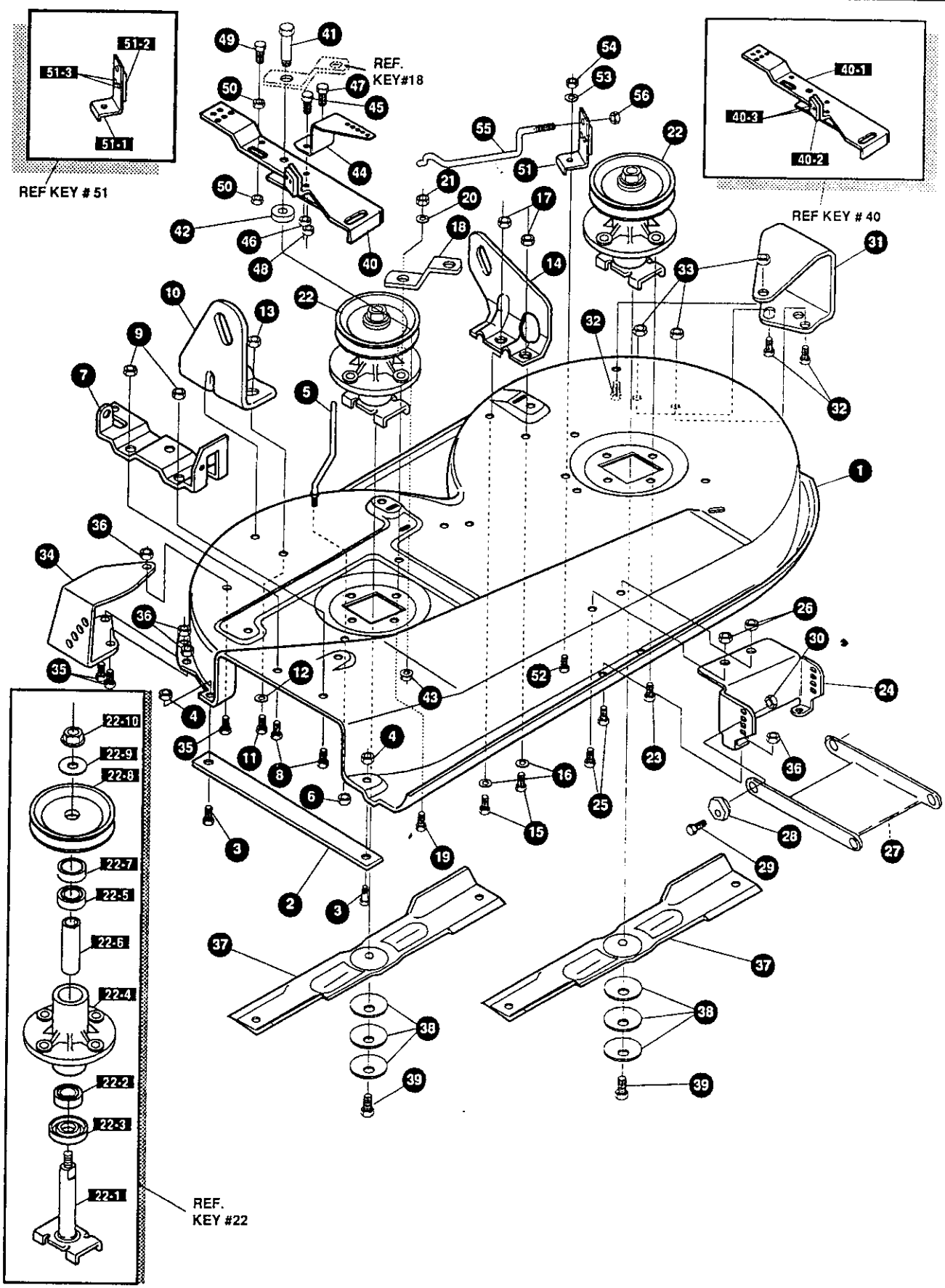

NOTE: ALWAYS USE ORIGINAL EQUIPMENT PARTS.
Use of service/replacement parts other than original equipment parts may void your warranty.

ALL UNNUMBERED ITEMS ARE INTERCHANGEABLE WITH OPPOSITE SIDE

332345 B

KEY#	PART#	DESCRIPTION	QTY
1	325106	39" DECK KIT	1
2	326295	BAR, SKID	1
3	126216	BOLT, 5/16-18 X .75 CARRLN	2
4	271184	NUT, 5/16-18 HEXKEPS	2
5	57318	GUIDE, BELT 5/16-18 THD	1
6	1498	NUT, 5/16-18 REGHEXCTRLK	1
7	313928	BRACKET, CHUTE BLACK, 853	1
8	180073	SCREW, 5/16-18 X .50 HHC	2
9	1498	NUT, 5/16-18 REGHEXCTRLK	2
10	313929	LIFT BRACKET, REAR, RH, BLACK, 853	1
11	180077	SCREW, 5/16-18 X .75 HHC	2
12	120393	WASHER, FLAT .344 X .69 X .065	2
13	1498	NUT, 5/16-18 REGHEXCTRLK	2
14	310667	BRACKET, DECK, LIFT REAR, LH, BLACK	1
15	180077	SCREW, 5/16-18 X .75 HHC	2
16	120393	WASHER, FLAT .344 X .69 X .065	2
17	1498	NUT, 5/16-18 REGHEXCTRLK	2
18	315302	BRACKET, IDLER SUPPORT	1
19	300345	SCREW, 5/16-18 X 1.38 WAHHTAP	1
20	120393	WASHER, FLAT .344 X .69 X .065	1
21	1498	NUT, 5/16-18 REGHEXCTRLK	1
22	56424	QUILL ASSEMBLY, 36/39/40/43	2
22-1	56425	SHAFT/SADDLE 36"	1
22-2	49562	BEARING, BALL 6203-2AA-C3 ARMORED	1
22-3	50616	DUST SHIELD	1
22-4	55547	QUILL CASTING (1046)	1
22-5	49562	BEARING, BALL 6203-2AA-C3 ARMORED	1
22-6	50818	SPACER, SLEEVE, .669 X .88 X 3.797	1
22-7	51449	SPACER, SLEEVE, .672 X .93 X .438	1
22-8	313898	PULLEY ASSEMBLY	1
22-9	56365	WASHER, SPECIAL QUILL	1
22-10		1282 NUT, 7/16-20 WDFLLK	1
23	35498	SCREW, 5/16-18 X .75 WAHHTAP	7
24	312526	LIFT, SUPPORT, FRONT DECK	1
25	180077	SCREW, 5/16-18 X .75 HHC	4
26	1498	NUT, 5/16-18 REGHEXCTRLK	4
27	58305	BRACKET, LINK DECK FRONT	1
28	58247	NUT, ADJUST	2
29	180079	SCREW, 5/16-18 X 1.00 HHC	2
30	1498	NUT, 5/16-18 REGHEXCTRLK	2
31	312477	WHEEL BRACKET, LH, BLACK	1
32	180077	SCREW, 5/16-18 X .75 HHC	3
33	1498	NUT, 5/16-18 REGHEXCTRLK	3
34	300102	WHEEL BRACKET, RH	1
35	180077	SCREW, 5/16-18 X .75 HHC	3
36	1498	NUT, 5/16-18 REGHEXCTRLK	3
37	309069	BLADE, 19.5, STD-LIFT, BLACK, 853	2
38	2483	WASHER, .39 ID X 1.25 D X .07 BELLVIL	6
39	39573	SCREW, 3/8-24 X 1.00 NYLHHC	2
40	300491	BRACKET, IDLER ARM/BRAKE	1
40-1	300490	IDLER ARM 36, 38, 39, & 45 SD	1
40-2	306973	BRAKE PAD - HARD-NF343 (X-31)	1
40-3	41601	RIVET, OVSET .187 DIA X .50 LONG	2
41	300180	BOLT, .50 X 1.88 HHSH, 3/8-16	1
42	996416	WASHER, FLAT .391 X 1.00 X .125	1
43	45171	NUT, 3/8-16 HWDFL WHIZ-LOCK	1
44	326249	BRACKET, EXTENSION IDLER	1
45	180077	SCREW, 5/16-18 X .75 HHC	1
46	1498	NUT, 5/16-18 REGHEXCTRLK	1
47	180020	SCREW, 1/4-20 X .75 HHC	1
48	1502	NUT, 1/4-20 REGHEXCTRLK	1
49	121954	SCREW, 1/4-20 X 2.00 HHC	1
50	271172	NUT, 1/4-20 REGHEXKEPS	2
51	303247	ASSEMBLY, BLADE BRAKE, 36, 39, 45	1
51-1	303246	BRAKE ARM	1
51-2	306973	BRAKE PAD - HARD-NF343 (X-31)	1
51-3	135624	RIVET, TRSET .185 DIA X .41 LONG	2
52	180077	SCREW, 5/16-18 X .75 HHC	1
53	120393	WASHER, FLAT .344 X .69 X .065	1
54	1498	NUT, 5/16-18 REGHEXCTRLK	1
55	300316	ROD, BRAKE RELEASE, 14.7, 39" DECK	1
56	1502	NUT, 1/4-20 REGHEXCTRLK	1

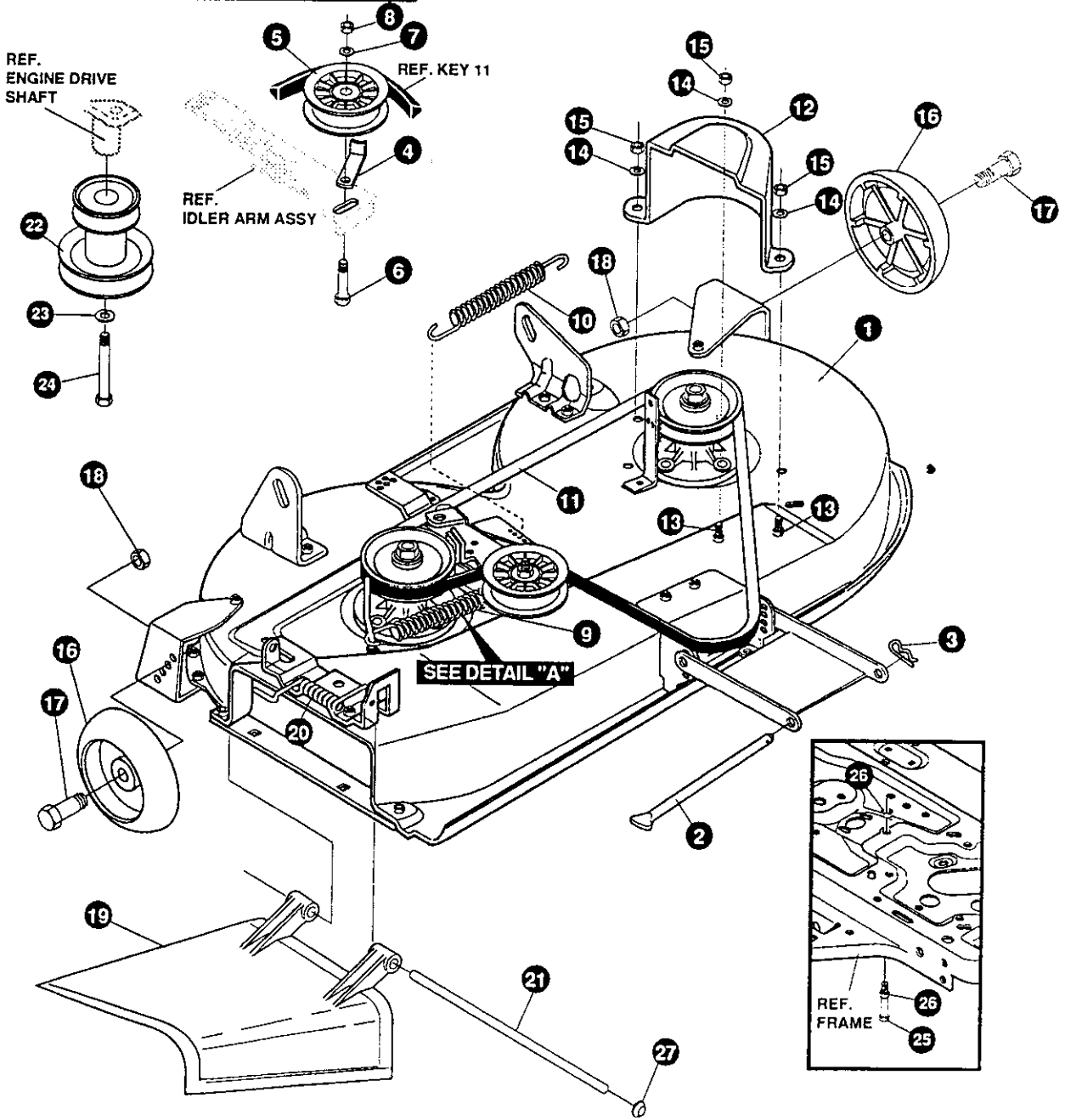
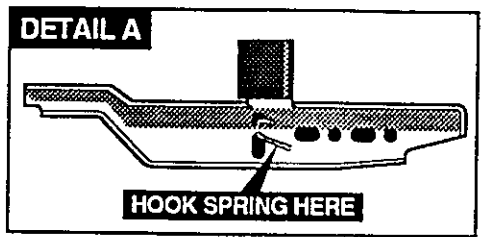

NOTE: ALWAYS USE ORIGINAL EQUIPMENT PARTS.
 Use of service/replacement parts other than original equipment parts may void your warranty.

ALL UNNUMBERED ITEMS ARE INTERCHANGEABLE WITH OPPOSITE SIDE

332346 B

KEY#	PART#	DESCRIPTION	QTY
1	329456	SUB ASSEMBLY DECK, SF, 39" SD	1
2	58306	ROD, DECK HITCH	1
3	8260	PIN, HAIR .091 DIA X 1.66 LONG	1
4	1346	RETAINER, BELT	1
5	310326	PULLEY, IDLER 8FF 4.00 WIDE FLANGE	1
6	57325	BOLT, 3/8-16 X 2.00 CARRSN	1
7	120382	WASHER, REGSPTLK .393 X .68 X .10	1
8	120377	NUT, 3/8-16 REGHX	1
9	322064	SPRING, .75 X 8.4 X .105 TENSION	1
10	326256	SPRING, .75 X 10.0 X .105 TENSION	1
11	300680	BELT, V 5L, 77.75, KEVLAR	1
12	328257	GUARD, BELT LH, PLASTIC	1
13	180077	SCREW, 5/16-18 X .75 HHC	3
14	120393	WASHER, FLAT .344 X .69 X .065	3
15	1498	NUT, 5/16-18 REGHEXCTRLK	3
16	302611	GAUGE WHEEL, EURO, 6.00 OD X 1.38 WD	2
17	23763	BOLT, .500 X 1.390 HSSH, 3/8-16	2
18	1499	NUT, 3/8-16 REGHXCTRLK	2
19	57818	CHUTE DEFLECTOR, 36", 39", 45"	1
20	314975	SPRING, TORSION CHUTE DEFLECTOR	1
21	334908	KIT FOR 57317 PIVOT ROD	1
22	328034	PULLEY, ENGINE, V3L, 4.00 OFFSET	1
23	120383	WASHER, REGSPTLK .459 X .78 X .12	1
24	433146	SCREW, 7/16-20 X 4.25 HHC, BLACK	1
25	180128	SCREW, 3/8-16 X 1.75 HHC	1
26	1499	NUT, 3/8-16 REGHXCTRLK	2
27	332179	CAP, PUSH ON, FOR DIA .250 ROD	1

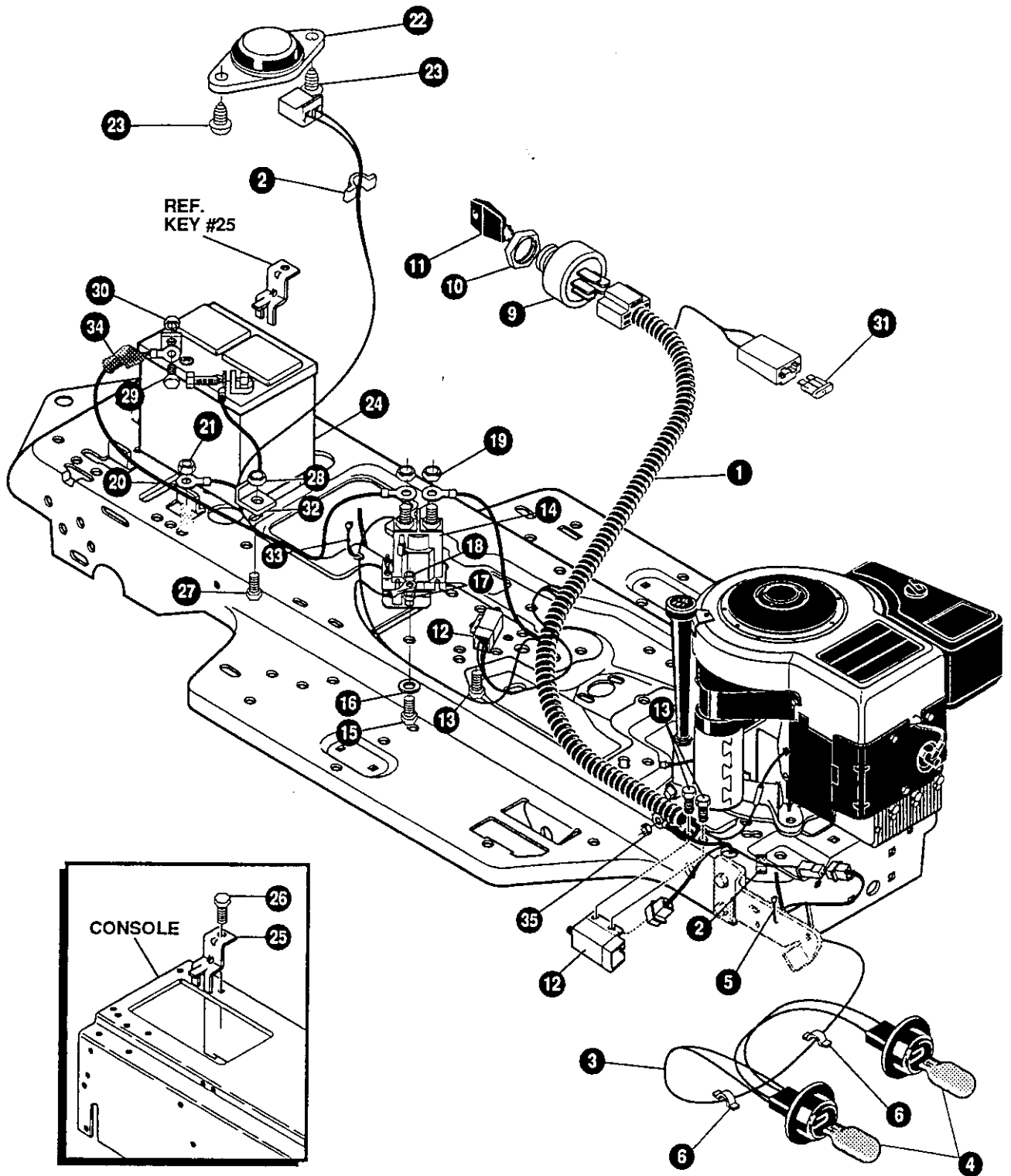

REF. KEY #25

CONSOLE

NOTE: ALWAYS USE ORIGINAL EQUIPMENT PARTS.
 Use of service/replacement parts other than original equipment parts may void your warranty.

ALL UNNUMBERED ITEMS ARE INTERCHANGEABLE WITH OPPOSITE SIDE

331669 C

KEY#	PART#	DESCRIPTION	QTY
1	331739	WIRE HARNESS, SF, 8-12HP, B&S	1
2	41482	PRESS CLIP, 1.380 LONG .255 ID	2
3	303064	ASSEMBLY, LIGHT WIRE-1/4 TURN	1
4	52572	BULB, HEADLAMP	2
5	57444	TIE, CABLE BLACK NYLON, 5.62 LONG	1
6	41482	PRESS CLIP, 1.380 LONG .255 ID	2
9	327354	SWITCH,IGNITION & LIGHTS DELTA	1
10	327352	NUT, 5/8-BACME DELTA FOR BOOT	1
11	327350 327349	KEY, IGNITION	1
12	57476	SWITCH, SCREW MOUNT, DP, NC, NO BLACK	2
13	300302	SCREW, #10 X .50 HHTAPPST, BLACK	4
14	53716	SOLENOID	1
15	187745	SCREW, 1/4-20 X .75 HXSEMMA	2
16	1084	WASHER, FLAT .281 X 1.00 X .063	1
17	1502	NUT, 1/4-20 REGHEXCTRLK	2
18	271172	NUT, 1/4-20 REGHEXKEPS	1
19	271187	NUT, 5/16-24 HKEPS	2
20	55511	WIRE, GROUND, 12.5"	1
21	271184	NUT, 5/16-18 HEXKEPS	1
22	57547	SWITCH, SEAT	1
23	160505	SCREW, 1/4-20 X .38 PHPNHMA	2
24	92693	BATTERY,12V, MAINTENANCE FREE	1
25	329175	BATTERY BRACKET	1
26	995346	SCREW, 1/4-20 X .50 WAHHTAP	1
27	187745	SCREW, 1/4-20 X .75 HXSEMMA	1
28	1502	NUT, 1/4-20 REGHEXCTRLK	1
29	180020	SCREW, 1/4-20 X .75 HHC	2
30	271172	NUT, 1/4-20 REGHEXKEPS	2
31	302031	FUSE, SPADE TYPE, 32V, 15A	1
32	9149	BRACKET, CABLE RETAINER	1
33	57444	TIE, CABLE BLACK NYLON, 5.62 LONG	1
34	308201	INSULATOR, BATTERY BOOT	1
35	124818	NUT, 1/4-20 REGHXJAM	1

SCHEMATIC DRAWING

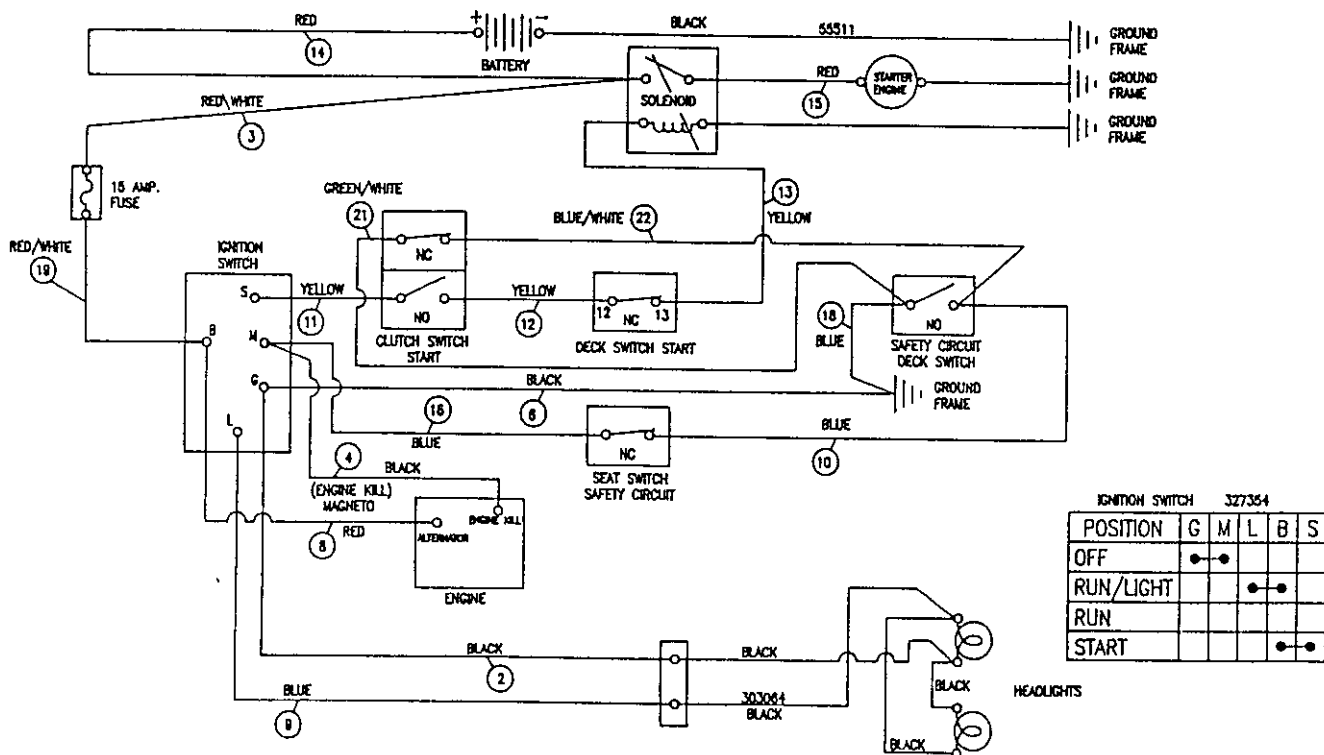

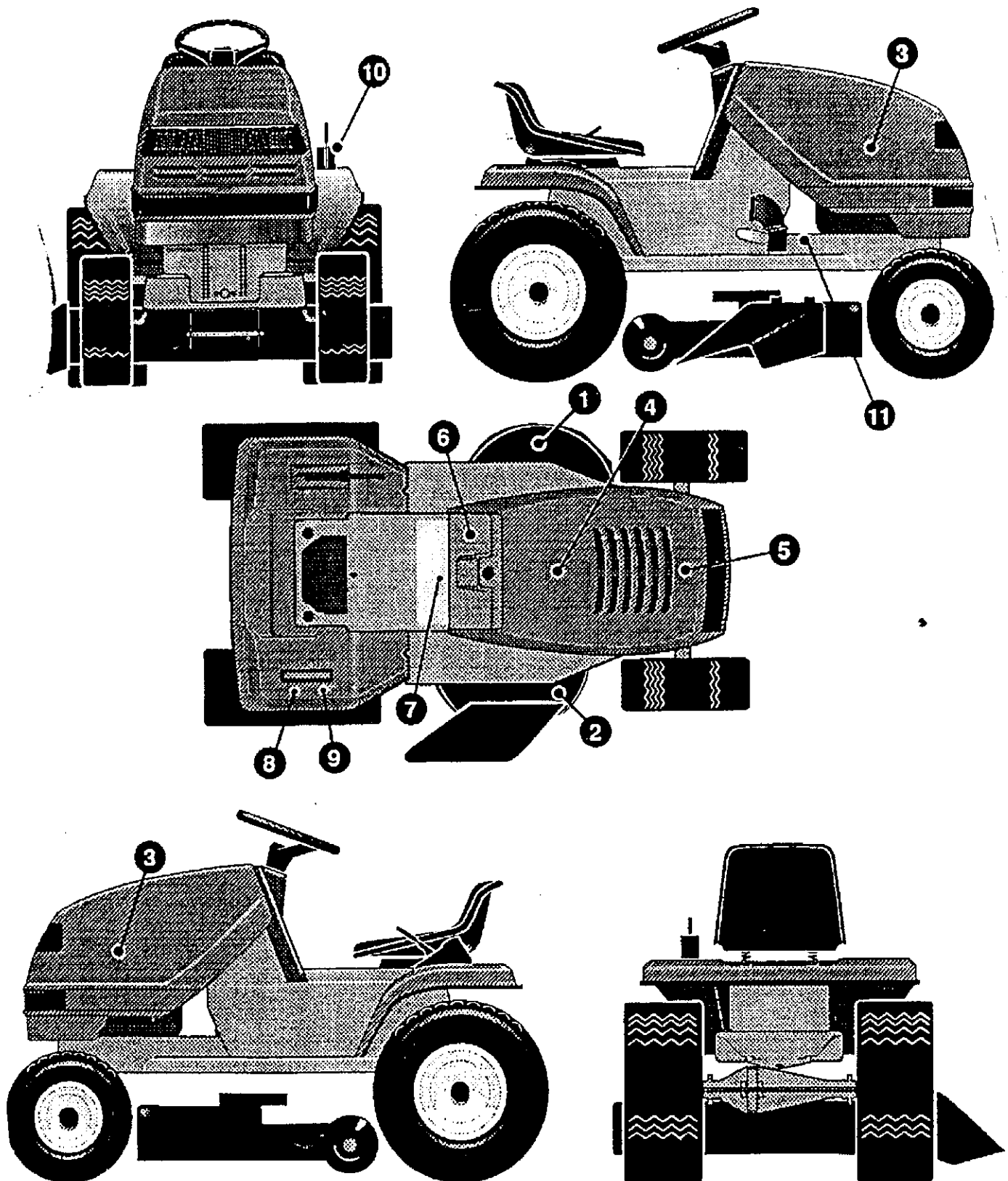

KEY#	PART#	DESCRIPTION	QTY
1	402700	DECAL, CAUTION, DECK, LH	1
2	402701	DECAL, CAUTION, DECK, RH	1
3	305603	PAD, 18 X 6 FOAM HOOD	2
4	307276	PAD, 15 X 7 FOAM HOOD	1
5	307277	PAD, 12 X 4 FOAM HOOD	1
6	326587	DECAL, DASH, EXPORT	1
7	402689	DECAL, CONSOLE, SYMBOLIC, CAUTION	1
8	311394	DECAL, SHIFT REVERSE/NEUTRAL	1
9	331013	DECAL, SHIFTER POSITION	1
10	402214	DECAL, HEIGHT ADJUST	1
11	402702	DECAL, BRAKE/CLUTCH	1

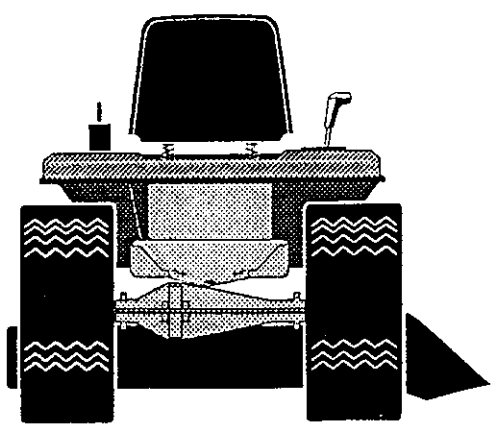
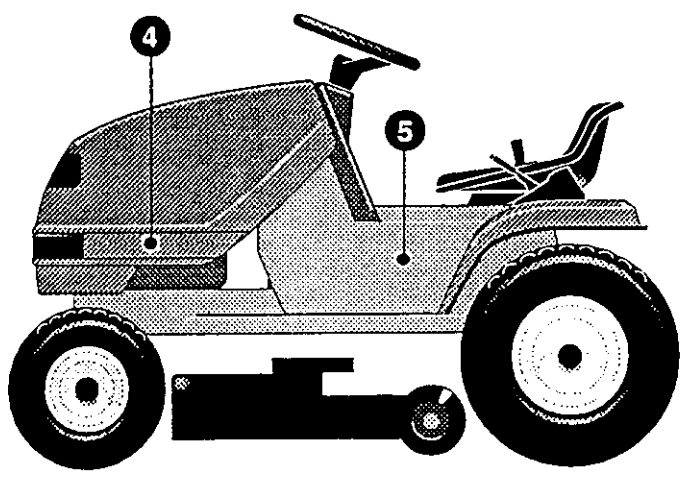
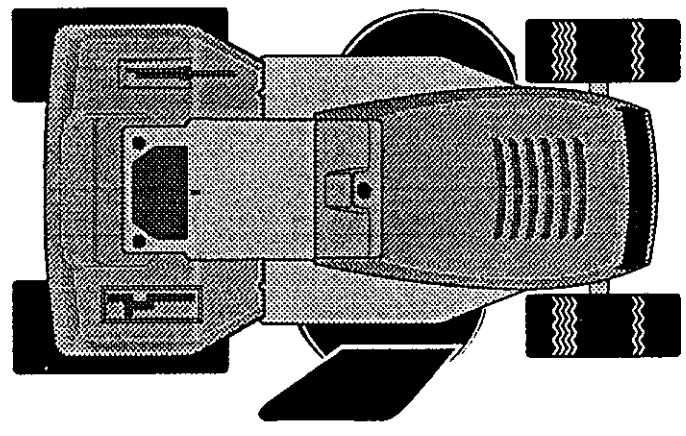
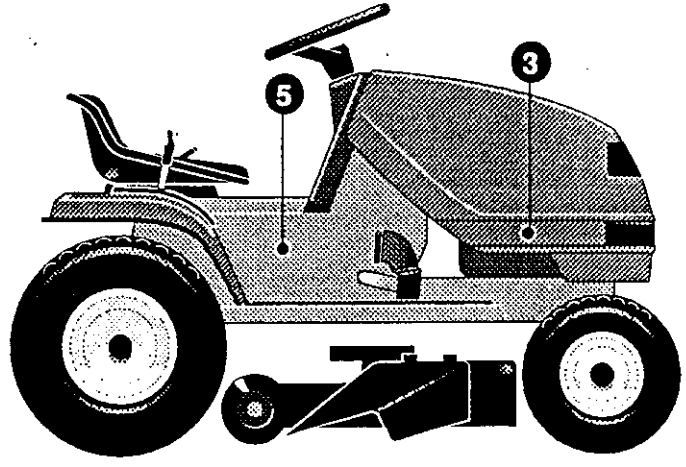
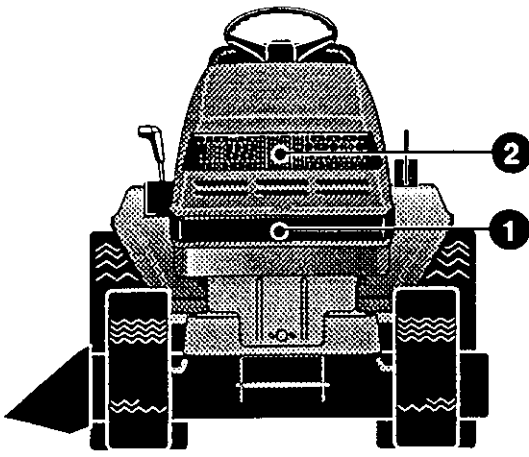

- 1 322699
- 3 402734
- 4 402733

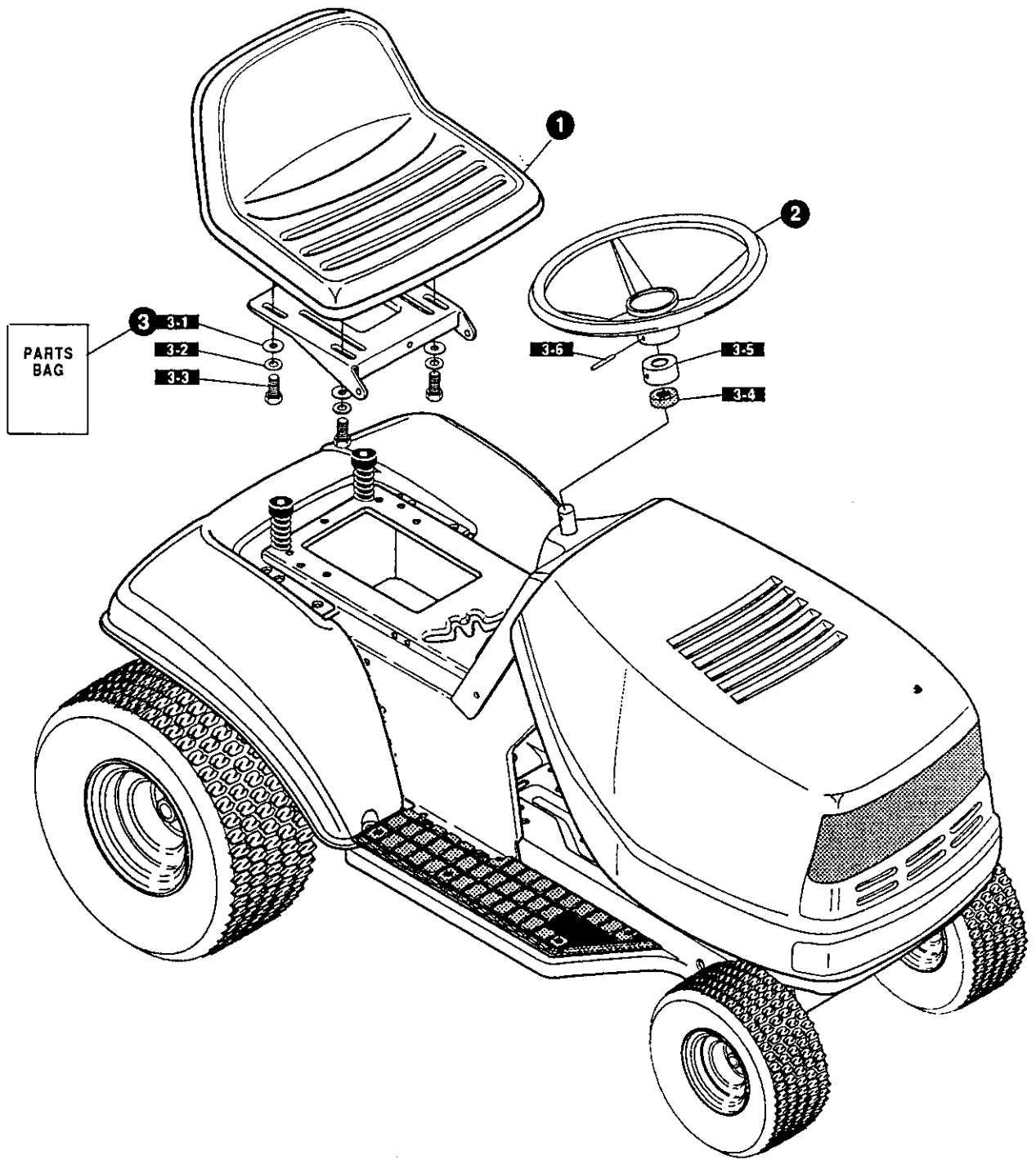

KEY#	PART#	DESCRIPTION	QTY
1	304316	SEAT, MICHIGAN GEN, W/SWITCH HOLE	1
2	330510	STEERING WHEEL	1
3	331424	PARTS BAG, ASSEMBLY SEAT/STEER	1
3-1	120393	WASHER, FLAT .344 X .69 X .065	4
3-2	120638	WASHER, HVSP TLK .328 X .60 X .09	4
3-3	180077	SCREW, 5/16-18 X .75 HHC	4
3-4	331322	COVER, STEERING SHAFT	1
3-5	301413	SPACER, STEERING SHAFT	1
3-6	456378	PIN, SPRING .250 DIA X 2.00 LONG	1

TREAD PATTERNS

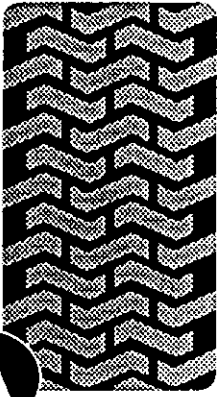

A

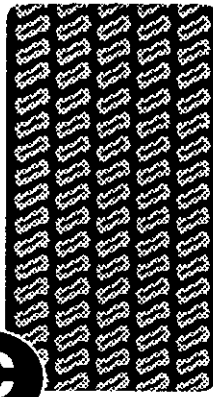

C

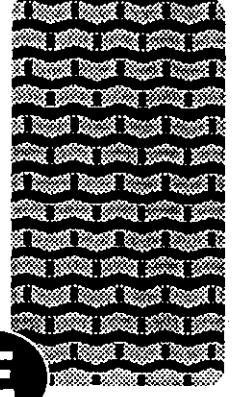

E

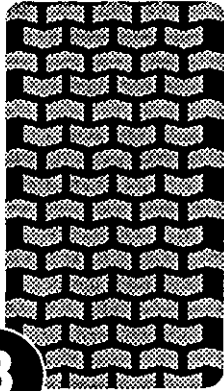

B

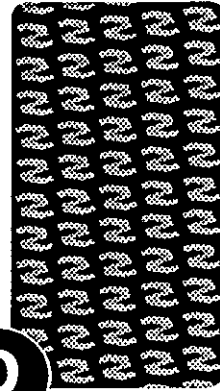

D

TIRE SIZE	"A"	"B"	"C"	"D"	"E"
11 X 4.00 - 5	42295	319679			
13 X 5.00 - 6	41060	319680			
15 X 6.00 - 6	39830	316702	301140	313952	
16 X 4.80 - 8		305035			
16 X 6.50 - 8	41081	319682		314539	
18 X 6.50 - 8		42091			
18 X 8.50 - 8	319683	317400			
18 X 9.50 - 8	41106	316701		313950	
20 X 8.00 - 8	319685	319684	57164	314584	331606
20 X 10.00 - 8	58276	319686		313654	
20 X 10.00 - 10	55893	319687			
23 X 9.50 - 12	53655	319690	319689	314370	