



Betjeningsvejledning

Texas Power Line Diesel motorer



TD420 / TD420E

TD600 / TD600E

TD900 / TD900E

Texas Andreas Petersen A/S
Knullen 2
DK-5260 Odense S
Tlf. 6395 5555 - Fax 6395 5558
post@texas.dk - www.texas.dk



- ADVARSEL** - Læs altid betjeningsvejledningen før brug af din motor.
- ADVARSEL** - Følg altid de retningslinjer, din lokale Texas Power Line forhandler giver med hensyn til Texas Power Line.
- ADVARSEL** - Stop altid din motor før opfyldning af brændstof.
- ADVARSEL** - Hvis spild forekommer, tør da altid grundigt op.
- ADVARSEL** - Hold altid motoren på afstand af brandbare væsker og andet brandfarligt.
- ADVARSEL** - Udstødningsgassen er farlig, brug derfor kun motoren, udenfor eller i et godt ventileret område.
- ADVARSEL** - Vær opmærksom på ikke at komme i kontakt med motorens bevægelige dele, under kørsel.
- ADVARSEL** - Vær opmærksom på ikke at komme i kontakt med motorens udstødning og blok, da den bliver meget varm under kørsel.
- ADVARSEL** - Brug aldrig motoren efter indtagelse af alkohol, narkotika eller andre rusmidler.

1. Indholdsfortegnelse

2. Montering	3
3. Brug af motoren	4
4. Olie / olieskift	4
5. Brændstof	5
6. Luffilter	6
7. Start - manuel	6
- elektrisk	7
8. Kørsel	7
9. Stop	8
10. Vedligeholdelse	8
11. Dimensioner	9
12. Dimension af PTO og ydelse	10
13. PTO	11
14. Elektrisk diagram – el-start	12

2. Montering

FREMGANGSMÅDE

1. Spænd motoren sikkert fast på basen.
2. Vær sikker på at motorens PTO er i lige linje med modtagerens PTO. Motor – Maskine.
En skæv PTO vil resultere i at motoren ikke trækker ordentlig, og vil blive beskadiget.

REMSKIVE

Hvis motoren trækker en maskine ved hjælp af en remskive, vær da altid sikker på at remskiven har den rigtige diameter.

SPØRGSMÅL

Hvis der opstår problemer eller spørgsmål omkring montering af din Texas Power Line Motor, er du altid velkommen til at kontakte din Lokale forhandler.

3. Brug af motoren

INDKØRING

De første 20 køretimer er motorens indkøringsperiode. Følg derfor altid de foregivne retningslinjer for brug af motoren.

1. Efter start, lad altid motoren varme op i mindst 5 minutter før brug., ved lave omdrejninger og minimal belastning.
2. Det anbefales at køre med motoren ved 3000 omdr / min, med kun 50% belastning de første 20 timer. Herefter er motoren kørt til kan køre med fuld belastning.
3. Skift olien efter de første 20 driftstimer.
4. Der efter for hver 50 driftstimer, eller en minimum gang årligt

4. Olie / olieskift

OLIE

Brug den rigtige olie for den rigtige årstid.

Over 20°	10-20°	Under 10°
SAE 30	SAE 20	SAE 10W - 30

OLIE KAPACITET

- Check altid olie niveauet, når motoren står vandret.
- Check altid olie niveauet uden at skrue oliepinde fast.

TD420	TD600	TD900
0,75 Liter	1,1 Liter	1,65 Liter

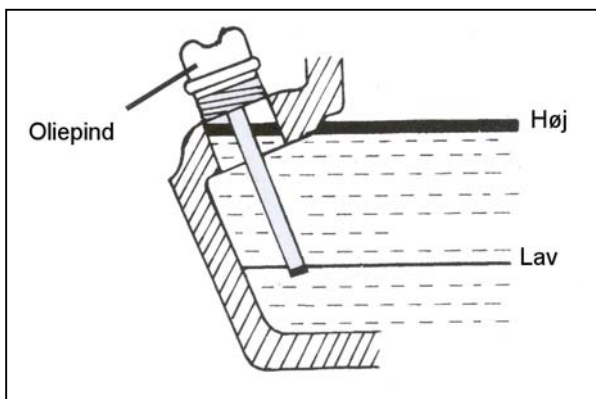

OLIESKIFT

Efter at motoren er indkørt, bør olien skiftes for hver 50 driftstimer.

1. Lad motoren køre 5 minutter, så olien når at blive varmet op. Dette gør at den løber lettere og at olieskiftet bliver mere komplet.
2. Efter minimum 5 minutter slukkes motoren. Motorens oliebundprop kan nu skrues løs, og olien løber ud af motoren. Husk at have en passende beholder klar.
3. Bundproppen kan nu skrues i på ny, og ny olie kan hældes i motoren.
4. Dette gøres ved at fjerne oliepipen og hælde den rigtige mængde olie på.

5. Brændstof

BRÆNDSTOF

Brug altid kun diesel brændstof på din motor. Samt den rigtige kapacitet
Overfyld aldrig din motor.

TD420	TD600	TD900
2,5 Liter	3,5 Liter	5,5 Liter

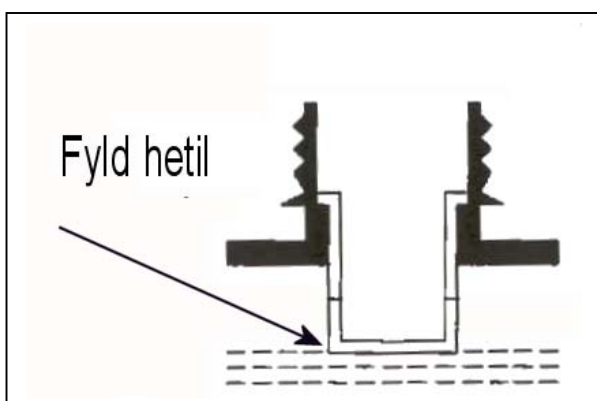

6. Luftfilter

LUFTFILTERET

Luftfilteret skal efterses og renses jævnligt. Hvis filteret ikke er blevet rensed i en længere periode, vil dette kunne mærkes på motorens kraftoverførsel, samt kunne ses på udstødningssgasen (den oser).

VIGTIGT: Er motoren monteret med papirelement. Må der under ingen omstændigheder komme olie på filteret.

1. Sku fingermøtrikken af, der holder dækslet til luftfilteret, og fjern dækslet
2. Tag forsigtigt filteret ud, og undersøg det. Udskift eller rengør hvis det er nødvendigt
3. Skumfilteret rengøres og vædes med lidt motorolie, det resterende olie presses ud med fingrene.

Der findes to slags luftfiltre:

1. Papir element, som skal skiftes for hver 500 driftstime.
2. Skum filter, der er vædet med motorolie. Skal renses for hver 500 driftstime, og skiftes for hver 1000 driftstime.
3. Hvis motoren kører i meget støvede omgivelser, kan rensning af luftfilter være nødvendig oftere.

Ved montering, vær da altid sikker på at alle dele slutter tæt. Utætheder kan resultere i at der kommer snavs ind i motoren, hvilket vil forkorte levetiden.

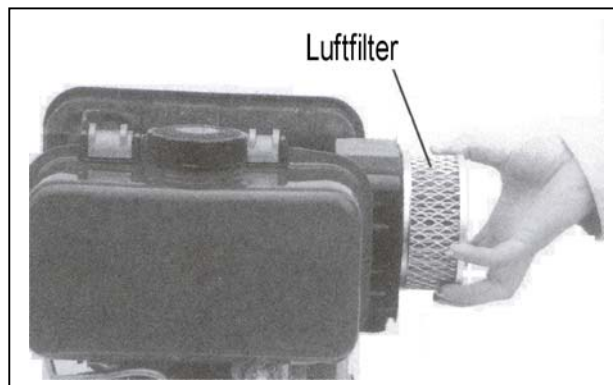

7. Start - Manuel

FREMGANGSMÅDE

1. Åben for brændstofhanen.
2. Drej reguleringshåndtaget til "start".
3. Drej dekompressions håndtaget ned (returnerer automatisk efter start.)
4. Træk langsomt i motorens startsnor, indtil der føles modstand. Træk derefter kraftigt i ét lang træk. Lad aldrig startsnoren løbe tilbage af sig selv, følg den altid tilbage med hånden.
5. Reguler gassen, indtil motoren har en jævn motorgang.

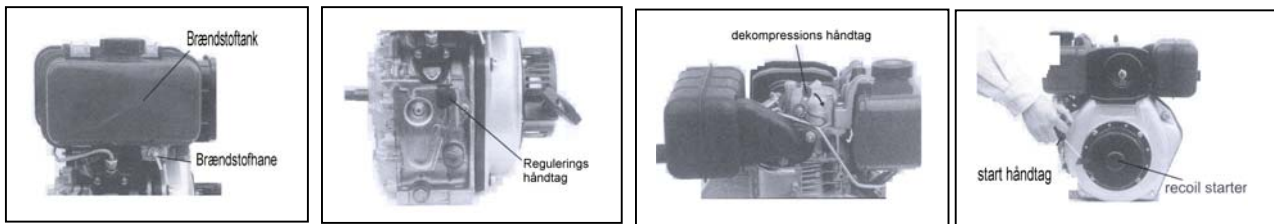

7. Start - Elektrisk

FREMGANGSMÅDE

6. Åben for brændstofhanen.
7. Drej reguleringshåndtaget til "start".
8. Drej start nøglen med uret til "start position".
9. Slip nøglen i det øjeblik, motoren starter.
10. Regulér gassen, indtil motoren har en jævn motorgang.

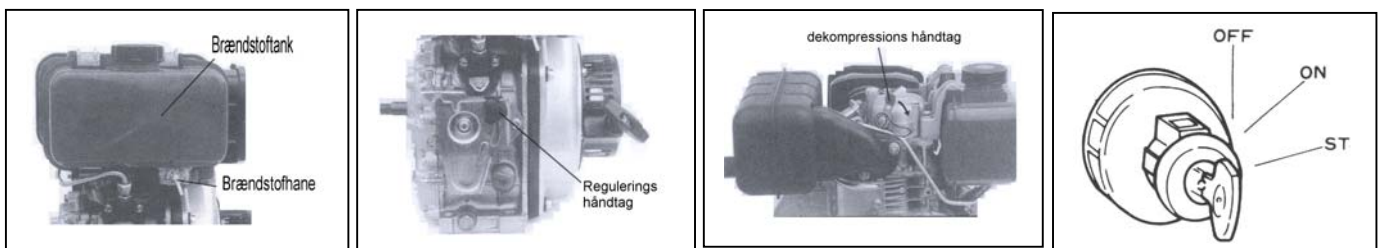

ADVARSEL

Hvis ikke nøglen slippes i det øjeblik motoren starter, vil motoren samt starter og batteri tage skade.

8. Kørsel

BEMÆRK

- Læg mærke til følgende under kørsel.
- Udstødningsgassen skal ikke være sort. Hvis dette forekommer, kan belastningen være for høj, motoren ikke er justeret korrekt, eller luftfilter er stoppet
- Ingen uregelmæssige lyde og vibrationer.
- Hvis dette forekommer, sluk motoren og juster motoren, kontakt evt. et autoriseret Texas Power Line værksted.

9. Stop

FREMGANGSMÅDE

1. Placer reguleringshåndtaget i "low" position og lad motoren køre lidt tid.
2. Placer derefter reguleringshåndtaget i "stop" position.
3. Drej brændstofhanen til "off"
4. Efter motoren er stoppet, træk da forsigtigt i motorens håndtag til rekylstart. Træk indtil der føles modstand, derved er lukket ind til motorblokken.
5. Hvis motoren er med el-start, drej da nøglen til "off" position.

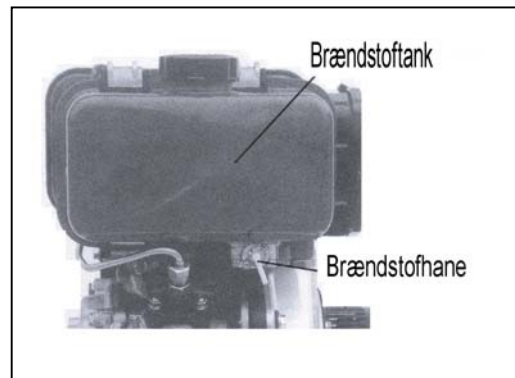
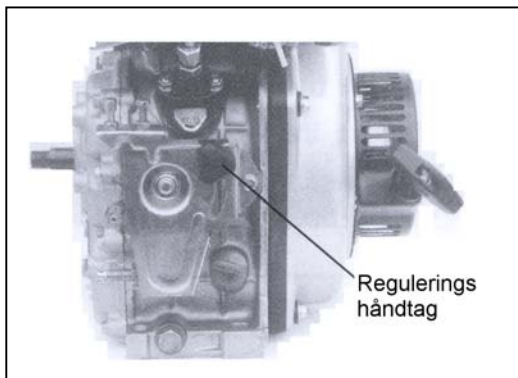

10. Vedligeholdelse

BEMÆRK

- Formålet med vedligeholdelsen er at holde motoren i bedst mulig stand.
- Reparationer bør altid blive udført på et autoriseret Texas Power Line værksted.

Del \ Interval	Interval						
	Hver gang	For hver 20 driftstimer	For hver 50 driftstimer	For hver 100 driftstimer	For hver 200 driftstimer	For hver 500 driftstimer	For hver 1000 driftstimer
Check bolte og møtrikker	X						
Check og påfyld olie	X						
Skift olie		X *					
Rens / skift olie filter		X (rens)	X (rens)				X (skift)
Check olie lækage	X						
Skift / kontroller luft filter						X **	
Rens brændstoffilter				X		X	X (skift)
Check dyse						X1	
Check brændstofpumpe						X1	
Juster ventiler						X1	
Check batteri	Hver måned						

* Olieskift bør som minimum ske mindst én gang om året.

** Ved drift i urene omgivelser, kan det være nødvendigt at rense/udskifte luftfilteret oftere.

14. Elektrisk diagram - el-start

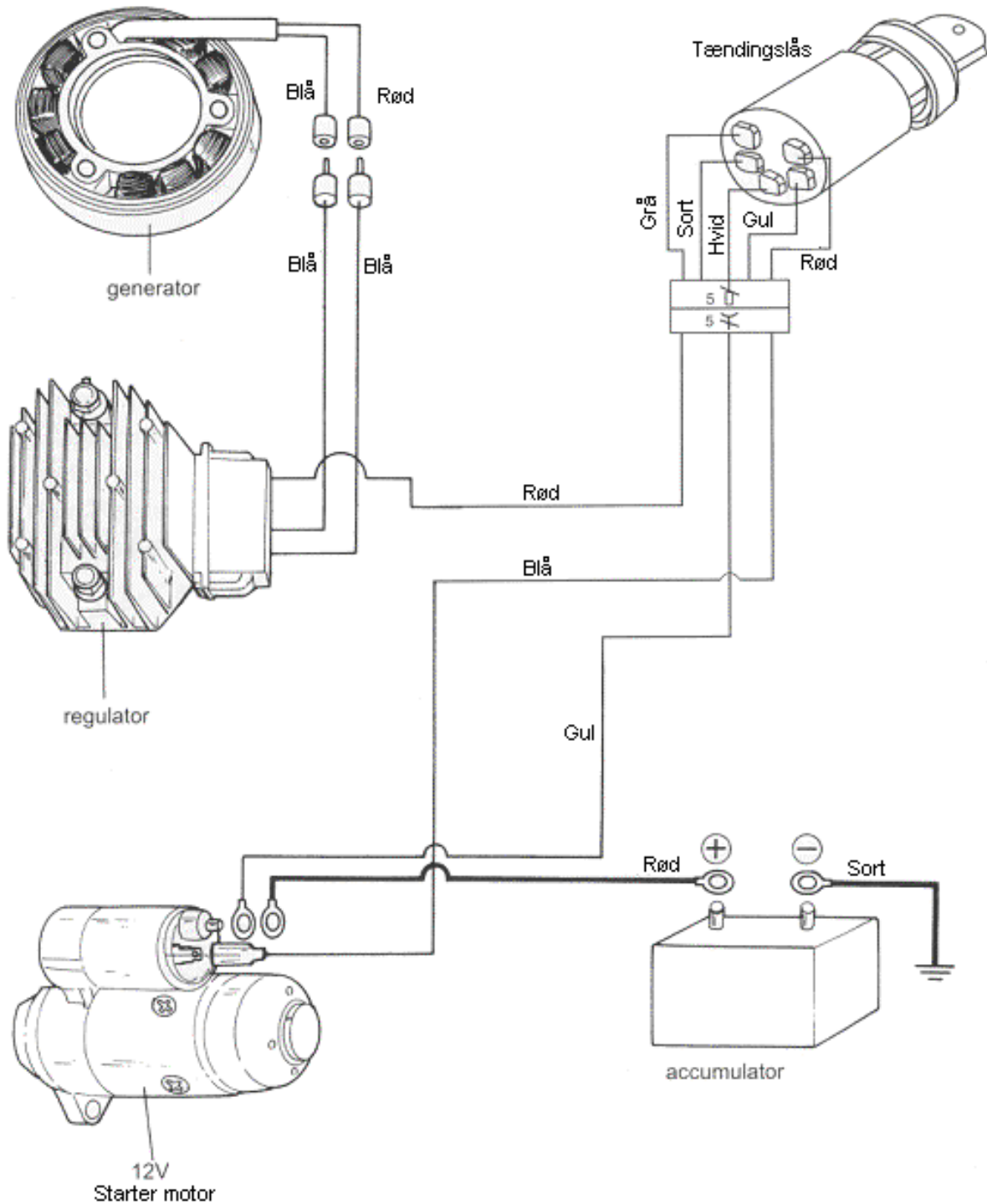

Grundet fortsat produkt udvikling, forbeholder Texas Andreas Petersen A/S sig ret til at ændre produktet, uden at være forpligtiget til at ændre allerede solgte modeller.



2003 / 2

User manual

Texas Power Line Diesel engines

TD420 / TD420E

TD600 / TD600E

TD900 / TD900E

Texas Andreas Petersen A/S
Knullen 2
DK-5260 Odense S
Ph. +45 6395 5555 - Fax +45 6395 5558
export@texas.dk - www.texas.dk



- Always read the user manual before use of the engine.
- Always follow the guidelines given by your Power Line dealer with regard to the engine.
- Always stop the engine before filling with fuel or oil.
- Always clean thoroughly if fluids are spilled.
- Always keep the engine at a distance from inflammable oils or other inflammable objects.
- Exhaust is dangerous, only use the engine outdoors or in a well ventilated area.
- Draw attention to not getting into contact with the engine's rotating parts during operation.
- Draw attention to not getting into contact with the engine's exhaust and the engine's block as it gets very warm during operation.
- Never use the engine under influence of alcohol or drugs.



1. Indholdsfortegnelse

2. Assembly	14
3. Use of the engine	15
4. Oil / changing oil	15
5. Fuel	16
6. Air filter	17
7. Start - manual	17
- electric	18
8. Operation	18
9. Stop	19
10. Maintenance	19
11. Specifications	20
12. Electric diagram – (electric-start)	22

2. Assembly

PROCEDURE

3. Fasten the engine securely onto the base.
4. Make sure that the engine's PTO is on a straight line with the receiver's PTO. Engine – Machine. An uneven PTO will result in the engine not pulling correctly and being damaged.

QUESTION

If problems arise or if you have any questions regarding the assembly of your Power Line engine, you are always welcome to contact your Power Line dealer.

3. Use of the engine

RUNNING-IN PERIOD

The first 20 hours is the running-in period for the engine. Therefore always follow the correct guidelines for use of the engine.

5. After start, let the engine pre-heat at low revolutions and minimum load at least 5 minutes before use
6. It is recommended to use the engine at 3.000 rpm and only 50% load the first 20 hours. After 20 hours, the engine is capable to run with full load.
7. Change the oil after the first 20 running hours.
8. If the oil is changed after the first 20 running hours, it is only necessary to change for every 50 running hours or minimum once every year.

4. Oil / changing oil

OIL

Use the correct oil for the specific time of year.

By 20° C	10-20° C	Below 10° C
SAE 30	SAE 20	SAE 10W - 30

OIL CAPACITY

- Always check the oil level when the engine is placed in a horizontal position.
- Always check the oil level without fastening the oil stick.

TD420	TD600	TD900
0,75 Liter	1,1 Liter	1,65 Liter

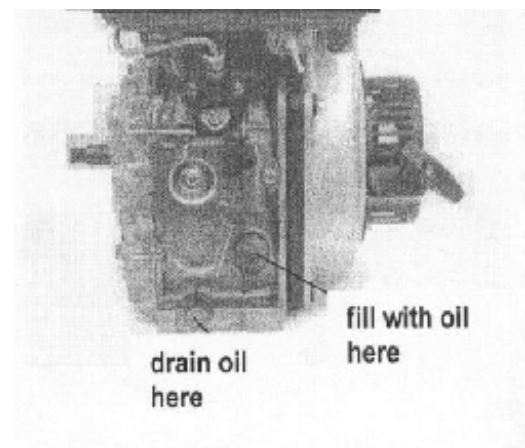
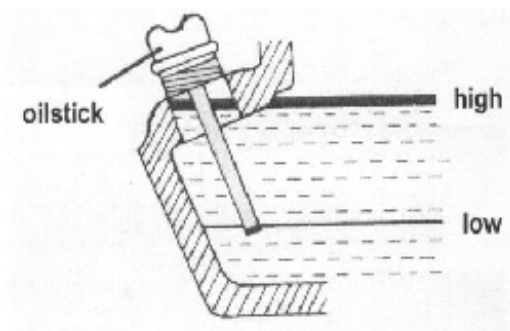

CHANGING OIL

Oil should be changed in accordance with the user manual for the machine.

5. Let the engine run 5 minutes, so that the oil is heated. This makes the oil flow more easily and it is easier to complete the oil change.
6. After 5 minutes the engine is turned off. Unscrew the engine's oil drain plug and the oil runs out of the engine. Remember to keep an appropriate container ready.
7. Put the drain plug back in its place and new oil is added to the engine.
8. You add oil by removing the oil stick and adding the correct amount of oil.

*Remember to dispose the used oil so that you are of no nuisance to the nature.
Use your local recycling station.*

5. Fuel

FUEL

Only use diesel fuel on your engine and the right capacity.
Never overflow the tank with gasoline.

TD420	TD600	TD900
2,5 Liter	3,5 Liter	5,5 Liter

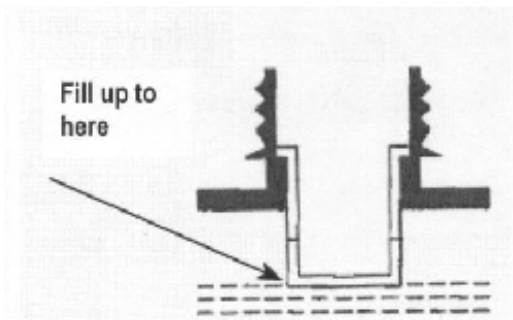

6. Air filter

AIR FILTER

Please inspect and clean the air filter on a regular basis. If the filter has not been cleaned for a longer period, this will be noticed on the engine's power take-off and the exhaustion (black smoke will appear).

IMPORTANT: If the engine is mounted with a paper element, oil must under no circumstances be applied on the filter.

1. Clean as follows.
2. Dismount the knurled nut, which fastens the cover to the air filter and remove the cover.
3. Remove the filter carefully and inspect it. Make sure no dirt gets in the carburettor.
4. Inspect thoroughly for cracks and holes, replace if necessary.
5. Remove the dust from the air filter by tapping the element easily a few times, or by blowing compressed air through the filter. Never try to brush away the dust. A brush will only push the dust further into the element. Replace the air filter if it is very dirty.
6. Put the element back in its place.
4. Draw attention to the parts being assembled correctly.

If the engine is running in a very dusted area it may be necessary to clean the air filter more often.

If you are in doubt that the air filter is mounted correctly, please contact your Power Line dealer.

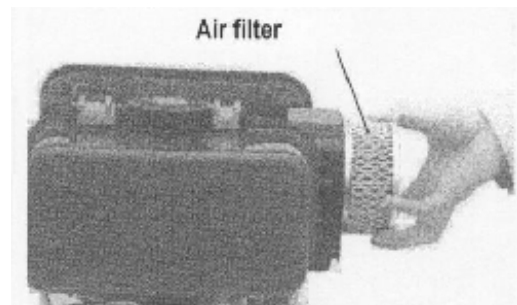
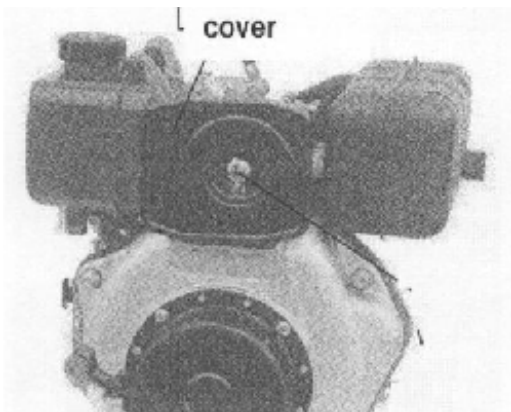

7. Start - Manual

PROCEDURE

11. Open the fuel tap.
 12. Turn the engines gas control to "start".
 13. Turn the decompression lever down, (it returns automatically after start)
 14. Pull the engine's starting cord slowly until you feel resistance. Thereafter pull in one long draw. Never let the starting cord run back by itself, always follow it with your hand.
- Regulate the gas until the engine is running evenly.

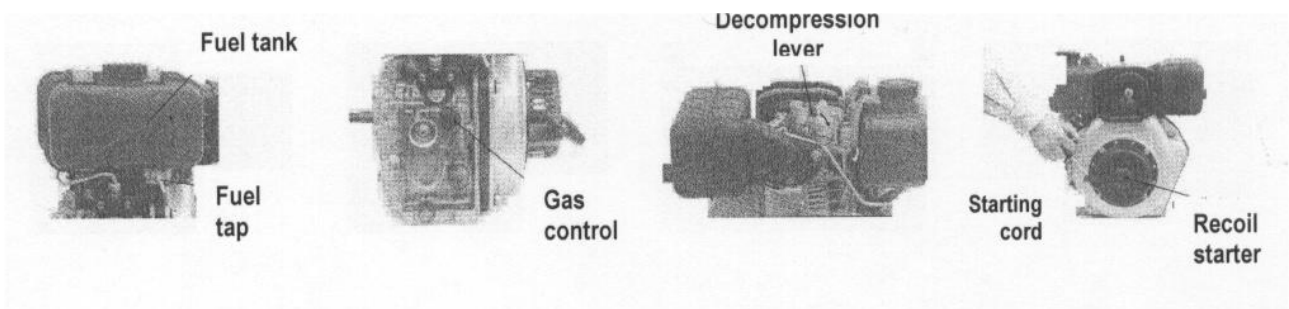

7. Start - Electric

PROCEDURE

1. Open the fuel tap
2. Turn the engine's gas control to "start".
3. Turn the key to the start position. If the engine does not start after 5 seconds, wait another 10 seconds and try again.
4. Regulate the gas control, until the engine is running evenly.

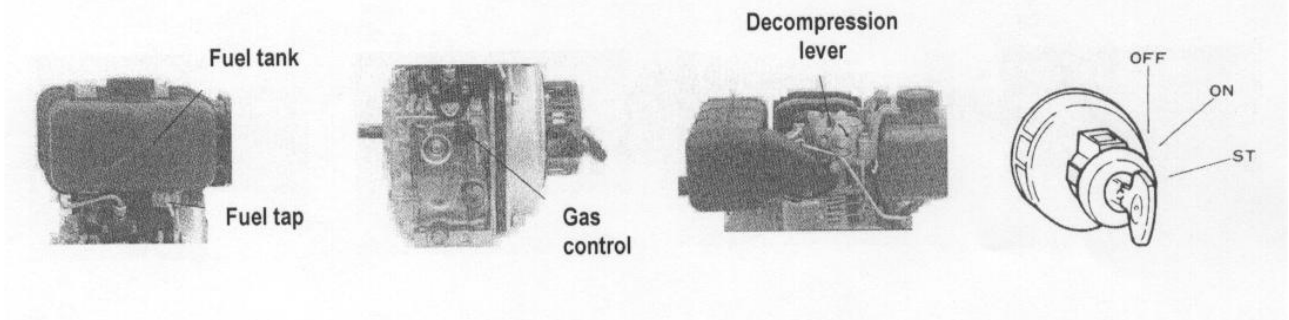

WARNING

Let go of the ignition key the moment the engine starts otherwise the engine's starter and battery will be damaged.

8. Operation

NOTE

- Please draw attention to the following during operation.
- Exhaustion must not be black. If the exhaustion is black the load is too high or the engine has not been adjusted correctly.
- No incorrect noises and vibrations. If these appear turn off the engine and adjust it. Contact your Power Line dealer.

9. Stop

PROCEDURE

6. Turn the gas control to a "low" position and let the engine run for a while.
7. Turn off the machine on the ignition switch.
8. Turn the fuel tap to the "off" position
9. If the machine is with electric-start, turn the key to the "off" position.

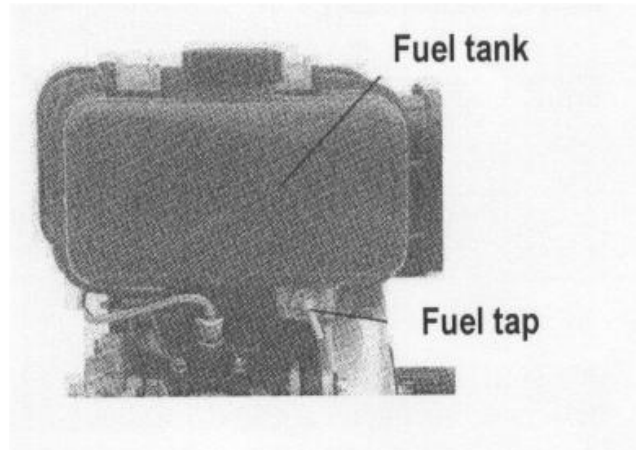
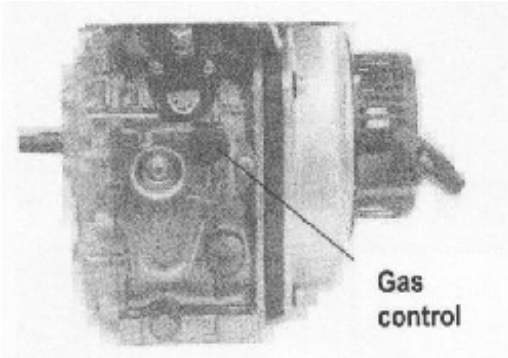

10. Maintenance

NOTE

- The purpose of maintenance is to keep the engine in its best possible shape.
- Repairs should always be carried out by an authorized Power Line dealer.

Part \ Interval	Interval						
	Every time	For every 20 running hrs	For every 50 running hrs	For every 100 running hrs	For every 200 running hrs	For every 500 running hrs	For every 1000 running hrs
Inspect bolts and nuts	X						
Inspect and fill with oil	X						
Change oil		X *					
Clean / change oil filter		X (clean)	X (clean)				X (change)
Inspect for oil leak	X						
Change / Inspect air filter						X **	
Check fuel pump						X1	
Adjust valves						X1	
Inspect valves	Every month						

* To keep the engine in best running order, oil change must take place, minimum once every year.

** By running the engine in a dusty environment, it is necessary to change / inspect the airfilter more often.



11. Specifications

Model	TD420 / TD420E	TD600 / TD600E	TD900 / TD900E
Type	4 stroke, air-cooled OHV, 1 cylinder, diesel engine		
Drilling x length of stroke mm	1-70 x 55	1-78 x 62	1-86 x 70
Stroke volume L	0,211	0,296	0,406
Max power kW (HP)	3,1 (4,2)	4,4 (6,0)	6,6 (9,0)
Constant power kW (HP)	2,8 (3,8)	4,0 (5,5)	6,3 (8,5)
Fuel	diesel		
Fuel capacity	2,5 L	3,5 L	5,5 L
Lubrication oil capacity	0,75 L	1,1 L	1,65 L
Regulating system	Mechanical		
Dimension (L x W x H), mm	305 x 365 x 335	313 x 376 x 335	
Dry weight, kg	26 / 31	33 / 38	48 / 53

12. Electrical diagram – electric start

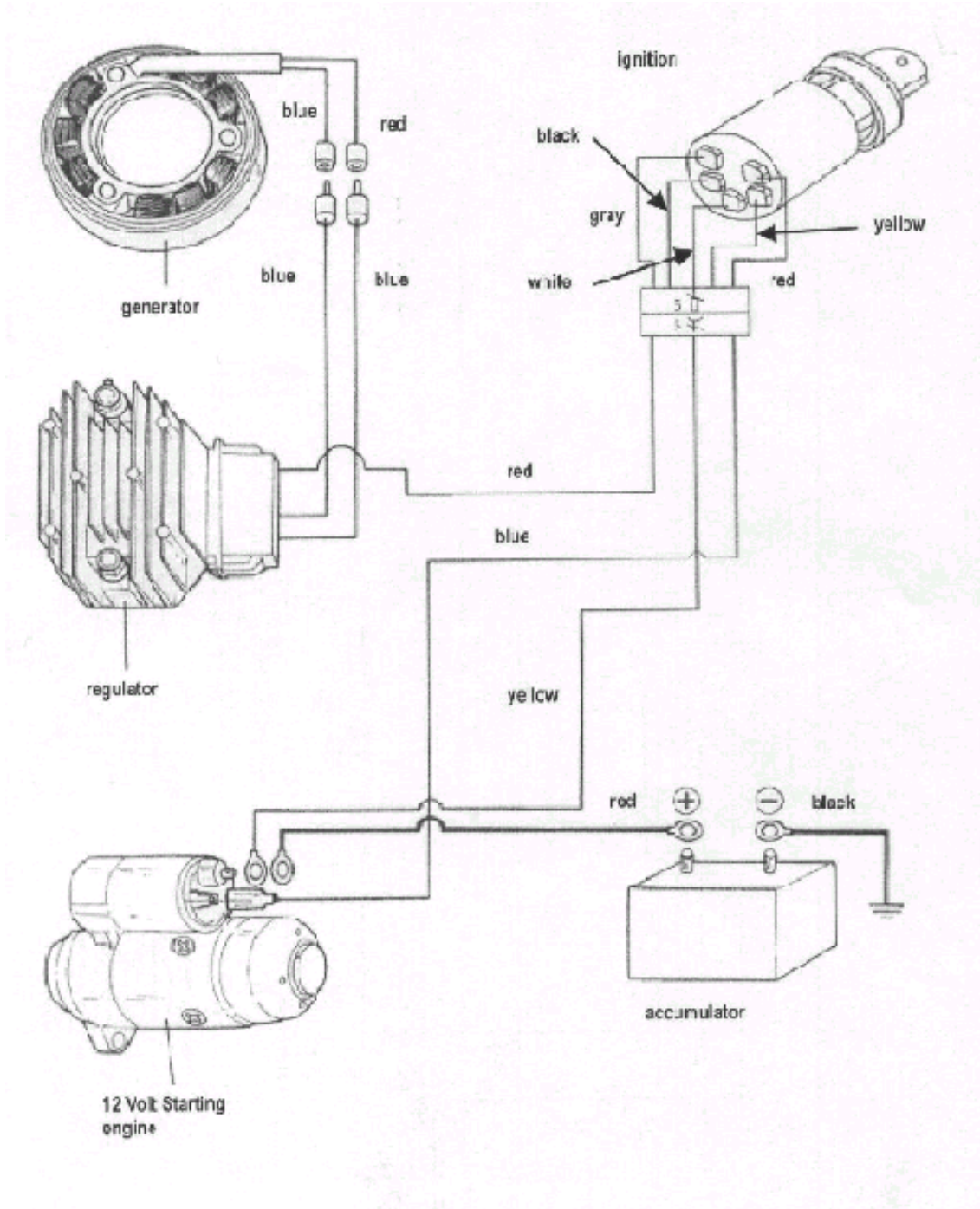

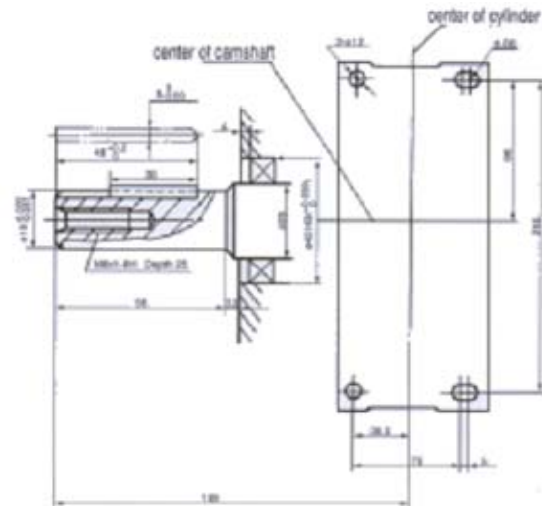

TD 420

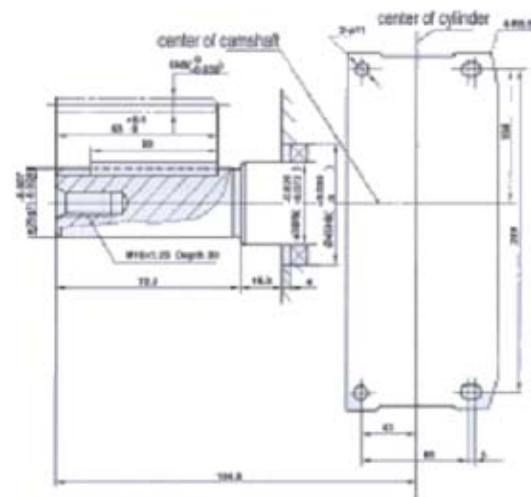

TD 600

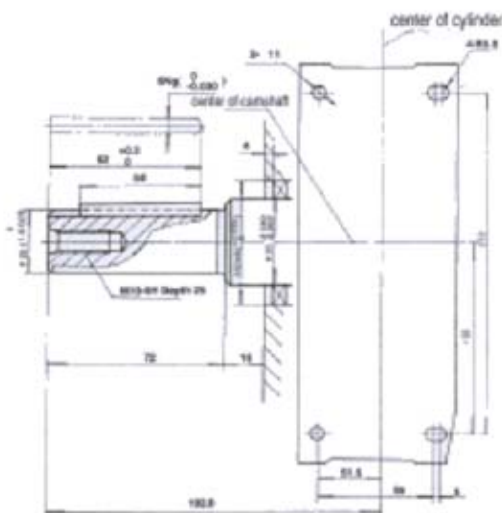

TD 900

Texas Andreas Petersen A/S reserves the right to change the product without being obligated to change already sold models.