

Rapid

3554-590

RESERVEDELSKATALOG

32" LAWN TRACTOR MODEL B3554-590

CHASSIS & HOOD ASSEMBLY

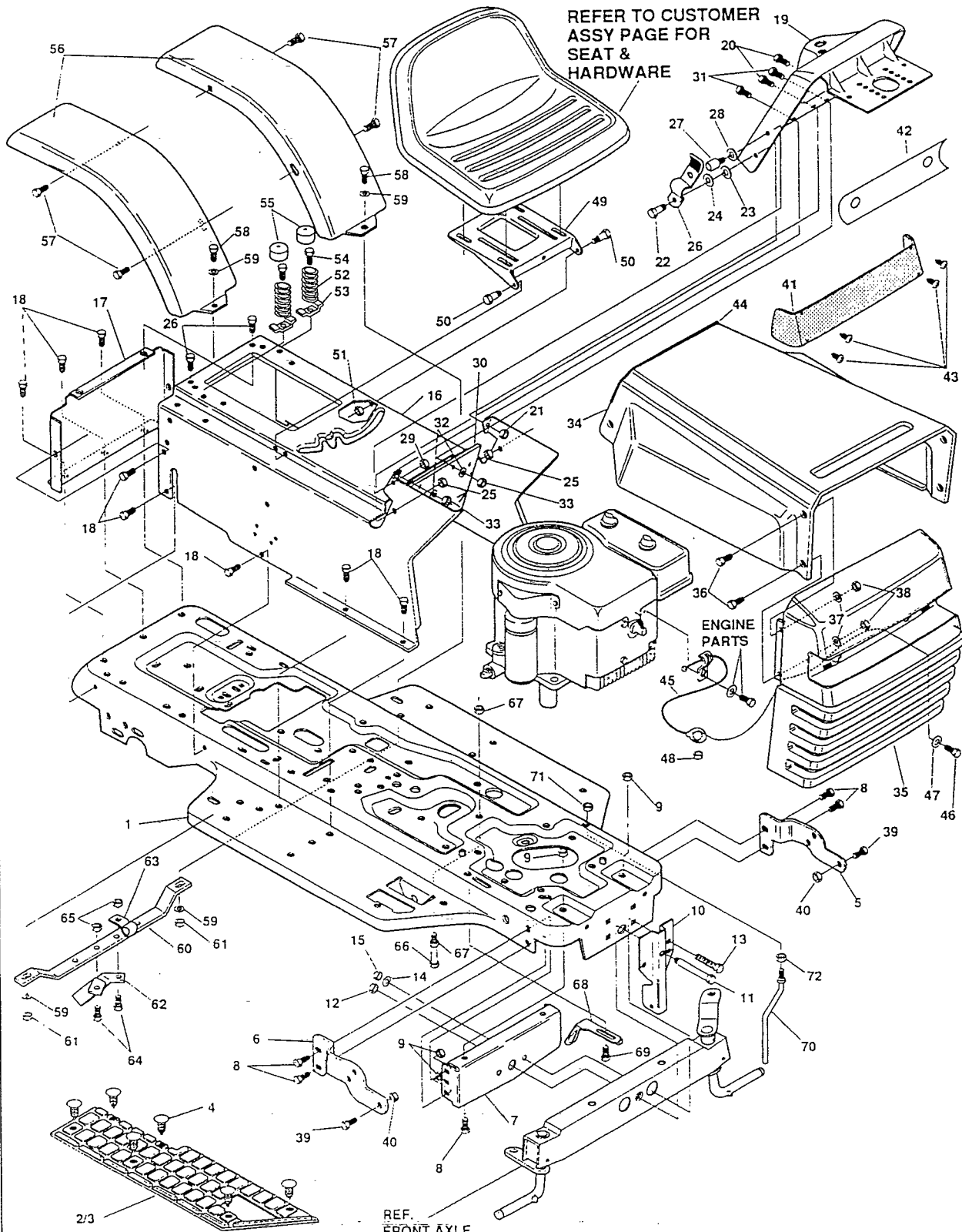

NOTE: ALWAYS USE ORIGINAL EQUIPMENT PARTS. Use of service/replacement parts other than original equipment parts may void your warranty.

ALL UNNUMBERED ITEMS ARE INTERCHANGABLE WITH OPPOSITE SIDE

317168A

32" LAWN TRACTOR MODEL B3554-590

key#	part#	description	qty.
1	315066	FRAME,MAIN SF RIDER	1
2	310003	FOOTPAD,LH	1
3	310004	FOOTPAD,RH	1
4	309235	FASTENER, RATCHET	12
5	316199	BRACKET,GRILLE L.H.	1
6	316200	BRACKET,GRILLE R.H.	1
7	313437	BRKT,SUPT FRT AXLE-	1
8	56030	SCREW, 5/16-18X.75WDFLLK	6
9	55273	NUT, 5/16-18 HXWDFLLK	6
10	8541	HANGER BRKT	1
11	50720	BOLT, .625X2.875 SPSH 1/2-20	1
12	0274654	NUT, 1/2-20 REGHXCTRLK	1
13	0122201	SCREW, 3/8-16X2.75 HHC	1
14	2483	WASHER,.39IDX1.25DX.07 BELLVIL	1
15	01499	NUT, 3/8-16 REGHXCTRLK	1
16	309751	CONSOLE	1
17	56235	CONSOLE, REAR COVER	1
18	0995346	SCREW, 1/4-20X .50 WAHHTAP	15
19	316113	DASH	1
20	0995338	SCREW, 1/4-20X .63 HHWATAP	2
21	50352	NUT 1/4-20 WDFLLK TOP LOCK	2
22	8482	BOLT, .375X .156 HSH 5/16-18	2
23	0120394	WASHER, FLAT .406X .81X.065	2
24	0120393	WASHER, FLAT .344X .69X.065	2
25	01498	NUT, 5/16-18 REGHEXCTRLK	2
26	57159	LATCH, .94WDX.047 ASSY HOOD	2
27	53446	PIN, 5/16-18 HOOD LATCH	2
28	0138538	WASHER, REGINTLK.320X.61X.03	2
29	045174	NUT, 5/16-18 HEXWDFLLK WHIZ	2
30	312306	BAFFLE CONSOLE SOUND EXPORT	1
31	0300314	SCREW, 1/4-20X .88WAHHTAP	2
32	0120393	WASHER, FLAT .344X .69X.065	2
33	01502	NUT, 1/4-20 REGHEXCTRLK	2
34	316489	HOOD	1
35	314476	GRILLE	1
36	0274672	SCREW, 1/4-20X .63 WAHHC	4
37	0120392	WASHER, FLAT .281X .63X.065	4
38	01502	NUT, 1/4-20 REGHEXCTRLK	4
39	36149	BOLT, .375X .500 HSH 5/16-18	2
40	01498	NUT, 5/16-18 REGHEXCTRLK	2
41	302333	LENS HEADLAMP	1
42	314948	FOIL, LENS DYNA-PRO REFLECTOR	1
43	057796	SCREW, #6 X .50 PLASTITE	4
44	47453	EDGING,WIDE BLK	25"
45	310748	LANYARD,HOOD	1
46	121887	SCREW 1/4-20 X .75 HHC	1
47	120392	FLATWASHER .281 X .63 X .065	1
48	1502	LOCKNUT 1/4-20	1
49	304761	PLATE, SEAT	1
50	20507	BOLT, .437X .156 HSH 5/16-18	2
51	01498	NUT, 5/16-18 REGHEXCTRLK	2
52	56220	SPRING,1.43X2.38X.162 COM SEAT	2
53	1341	CLAMP,SPRING 1.17"ID	2
54	0995346	SCREW, 1/4-20X .50 WAHHTAP	2
55	302099	SPRING COVER, SEAT	2
56	3606	FENDER	2
57	0995346	SCREW, 1/4-20X .50 WAHHTAP	4
58	0122017	SCREW, 5/16-18X1.00 HHC	2
59	0446363	WASHER, FLAT .375X .88X.082	4
60	43964	SUPPORT GUIDE	1
61	01498	NUT, 5/16-18 REGHEXCTRLK	2
62	49899	REAR DECK GUIDE	1
63	57569	RETAINER, .31 ID X .62 X .03 WIRE	1
64	122017	SCREW 5/16-18 X 1.00 HHC GR2	2
65	1498	NUT 5/16-18 REGHEXCTRLK	2
66	049930	SCREW, 3/8-16X 6.50 HHC	1
67	01499	NUT, 3/8-16 REGHEXCTRLK	2
68	312953	BRACKET,SWITCH MOUNT	1
69	0995346	SCREW, 1/4-20X .50 WAHHTAP	1
70	50653	GUIDE, BELT	1
71	041529	NUT, 3/8-16 HXCTRLKJAM	1
72	0271190	NUT, 3/8-16 HEXKEPS	1
73	318234	OWNER'S MANUAL (NOT ILLUSTRATED)	1

◊ Indicates STANDARD HARDWARE ITEMS.

32" LAWN TRACTOR MODEL B3554-590

STEERING ASSEMBLY

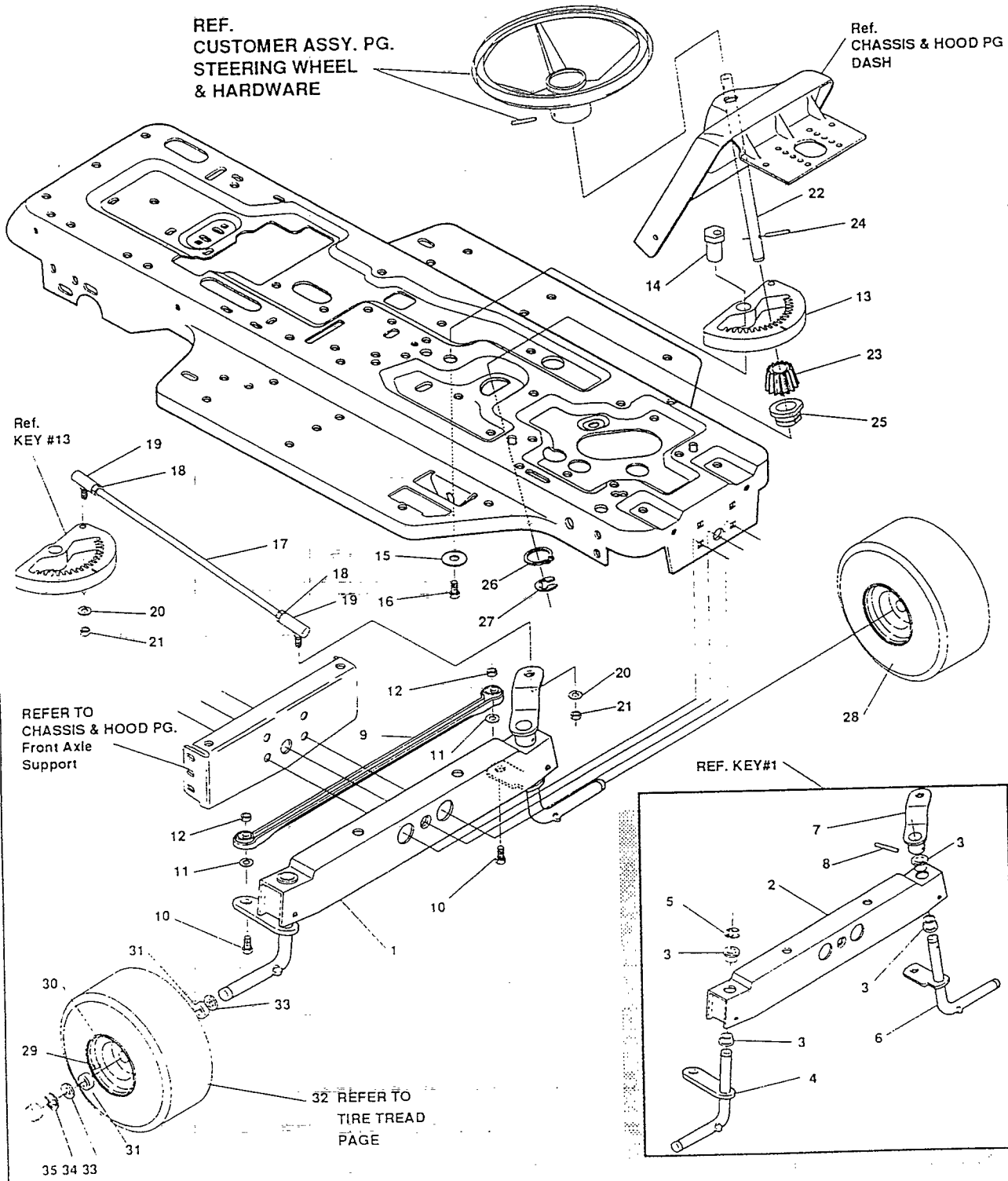

ALL UNNUMBERED ITEMS ARE INTERCHANGABLE WITH OPPOSITE SIDE

NOTE: ALWAYS USE ORIGINAL EQUIPMENT PARTS. Use of service/replacement parts other than original equipment parts may void your warranty.

315005B

32" LAWN TRACTOR MODEL B3554-590

key#	part#	description	qty.
1	*	FRONT AXLE ASSEMBLY SF	1
2	56400	AXLE, FRONT	1
3	50546	BEARING, FLANGE	4
4	310368	SPINDLE, RH	1
5	36625	RING, RETEX	1
6	310367	SPINDLE, LH	1
7	49447	ARM, STEERING LH	1
8	454565	PIN, SPRING	1
9	302691	TIE ROD	1
10	◇ 122145	SCREW, 3/8-16X1.25 HHC	2
11	◇ 120382	WASHER, .393X.68X.10 REGSPTLK	2
12	◇ 1499	NUT, 3/8-16 REGHCTRLK	2
13	304245	SECTOR, GEAR	1
14	44011	BOLT, .750X1.40 SPSH	1
15	2483	WASHER, .39IDX1.25ODX.07	1
16	39573	SCREW, 3/8-24X1.00 NYL	1
17	56190	DRAG LINK	1
18	◇ 124925	NUT, 3/8-24 REGHEXJAM	2
19	21275	BALL JOINT	2
20	◇ 120382	WASHER, REGSPTLK	2
21	◇ 120369	NUT, 3/8-24 REGHEX	2
22	314109	STEERING SHAFT	1
23	44009	PINION, STEERING SHAFT	1
24	454565	PIN, SPRING	1
25	54902	BEARING, 1.370X.50 FLANGE STEERING	1
26	39492	RING, RETEX 1.27X.05	1
27	36625	RING, RETEX .57X.05	1
28	*	ASSEMBLY, TIRE & RIM	2
29	24167	VALVE STEM	1
30	39937	WHEEL W/BEARING	1
31	39979	BEARING, 1.38ODX.753ID FLANGE	2
32		REFER TO TIRE TREAD PAGE	
33	642	WASHER, FLAT .755X1.31X.075	4
34	36625	RING, RETEX .57X.05	2
35	40394	HUB CAP	2

* ORDER INDIVIDUAL PARTS.

◇ Indicates STANDARD HARDWARE ITEMS.

32" LAWN TRACTOR MODEL B3554-590

MOTION DRIVE ASSEMBLY

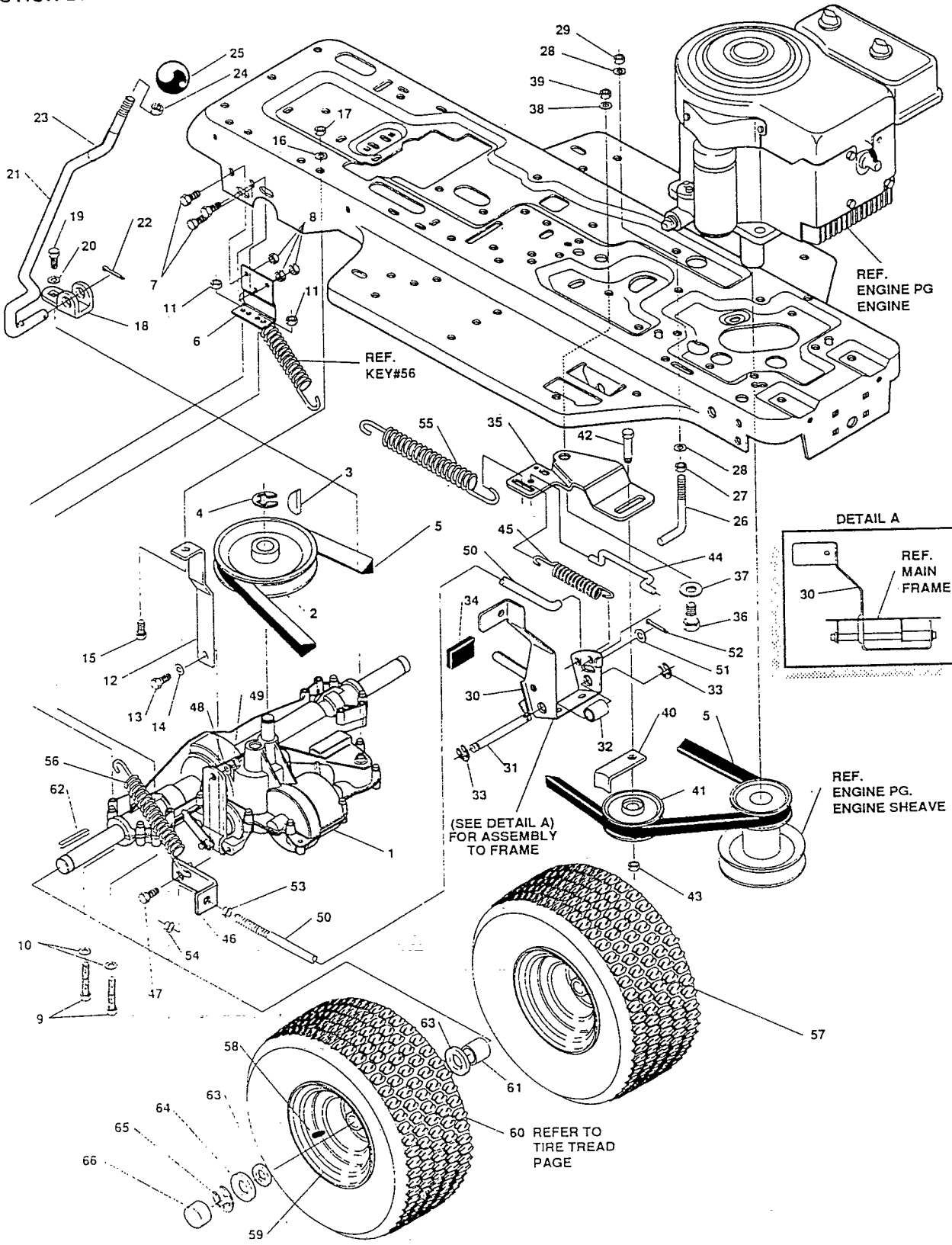

NOTE: ALWAYS USE ORIGINAL EQUIPMENT PARTS. Use of service/replacement parts other than original equipment parts may void your warranty.

ALL UNNUMBERED ITEMS ARE INTERCHANGABLE WITH OPPOSITE SIDE

314985A

2" LAWN TRACTOR MODEL B3554-590

key#	part#	description	qty.
1	TRANSAXLE	FOOTE 4360-3 (CONTACT NEAREST DEALER)	1
2	302745	PULLEY,V 4L 6.60 OD	1
3	3021	KEY, WDRF 606 .750X.187X.312	1
4	22053	RING, RETEX .58X.04TRU5100-62	1
5	54758	BELT, V 4L 82.00 SF DRIVE	1
6	7707	BRACKET, TRANSAXLE	2
7	◊120228	SCREW, 5/16-18X .63 HHC	6
8	◊1498	NUT, 5/16-18 REGHEXCTRLK	6
9	◊180112	SCREW, 5/16-18X2.75 HHC	4
10	120393	WASHER, FLAT .344X .69X.065	4
11	◊1498	NUT, 5/16-18 REGHEXCTRLK	4
12	309770	BRKT,STABILIZER 920,4360	1
13	◊35498	SCREW, 5/16-18X .75 WAHHTAP	1
14	120638	WASHER, HVSP TLK .328X.60X.09	1
15	◊122017	SCREW, 5/16-18X1.00 HHC	1
16	138485	WASHER, EXLK .320X.61X.03	1
17	◊1498	NUT, 5/16-18 REGHEXCTRLK	1
18	57480	BRKT,SHIFT P920-5/F4360-5&3	1
19	◊56255	SCREW, 1/4-28X .75 NYLHHC	1
20	57157	WASHER,.750X.250	1
21	302283	SHIFT LEVER	1
22	137185	PIN, COTTER .125 DIA X1.00LG	1
23	302445	TUBE,CLEAR PLASTIC	1
24	◊120238	NUT, 1/2-13 HEXJAM	1
25	304438	KNOB,SHIFT NOMA 1/2-13	1
26	49896	BELT GUIDE -	1
27	◊271184	NUT, 5/16-18 HEXKEPS	1
28	120393	WASHER, FLAT .344X .69X.0652	2
29	◊1498	NUT, 5/16-18 REGHEXCTRLK	1
30	302603	ASSY,BRAKE PEDAL	1
31	302600	ROD,PIVOT	1
32	302601	SPACER,.53ID X.62DX1.406	1
33	20864	RING, RET E .39X.04TRU5133-50	2
34	48761	PAD,CLUTCH/BRAKE PEDAL	1
35	1306	IDLER ARM BRKT TRACTION	1
36	41890	BOLT, .625X .218 HSSH 5/16-18	1
37	4107	WASHER, FLAT .635X1.31X.07	1
38	45602	WASHER, FLAT .333X .87X.119	1
39	◊1498	NUT, 5/16-18 REGHEXCTRLK	1
40	39659	RETAINER, STRAP BELT	1
41	35374	PULLEY, IDLER	1
42	45892	BOLT, 3/8-16X1.50 CARR	1
43	◊1499	NUT, 3/8-16 REGHXCTRLK	1
44	43980	ROD, .268 DIA CLUTCH	1
45	50562	SPRING,3/8OD X1.625X.055	1
46	54723	BRACKET, BRAKE ROD	1
47	20507	BOLT, .437X .156 HSSH 5/16-18	1
48	120393	WASHER, FLAT .344X .69X.065	1
49	◊1498	NUT, 5/16-18 REGHEXCTRLK	1
50	310189	BRAKE ROD	1
51	120393	WASHER, FLAT .344X .69X.065	1
52	121222	PIN, COTTER .090/.086X.75LG	1
53	◊271184	NUT, 5/16-18 HEXKEPS	1
54	◊1498	NUT, 5/16-18 REGHEXCTRLK	1
55	49276	SPRING,3/4 ODX6.75X.091	1
56	35410	SPRING .071 X .62 X 4.37	1
57	.	TIRE&RIM ASM,18X6.50-8	2
58	24167	VALVE STEM	1
59	36182	WHEEL HUB	1
60	.	REFER TO TIRE TREAD PAGE	
61	57479	SPACER, .75 X 1.25 X 1.32	2
62	39628	KEY, SQUARE .187SQ X2.50L	2
63	642	WASHER, FLAT .755X1.31X.075	4
64	42815	WASHER, FLAT .755X1.53X.07	2
65	36625	RING, RETEX .57X.05TRU5133-75	2
66	40394	CAP, 1.500ID X 7/8LG HUB	2

* Order Individual Parts.

◊ Indicates STANDARD HARDWARE ITEMS.

32" LAWN TRACTOR MODEL B3554-590

ENGINE & CONTROL ASSEMBLY

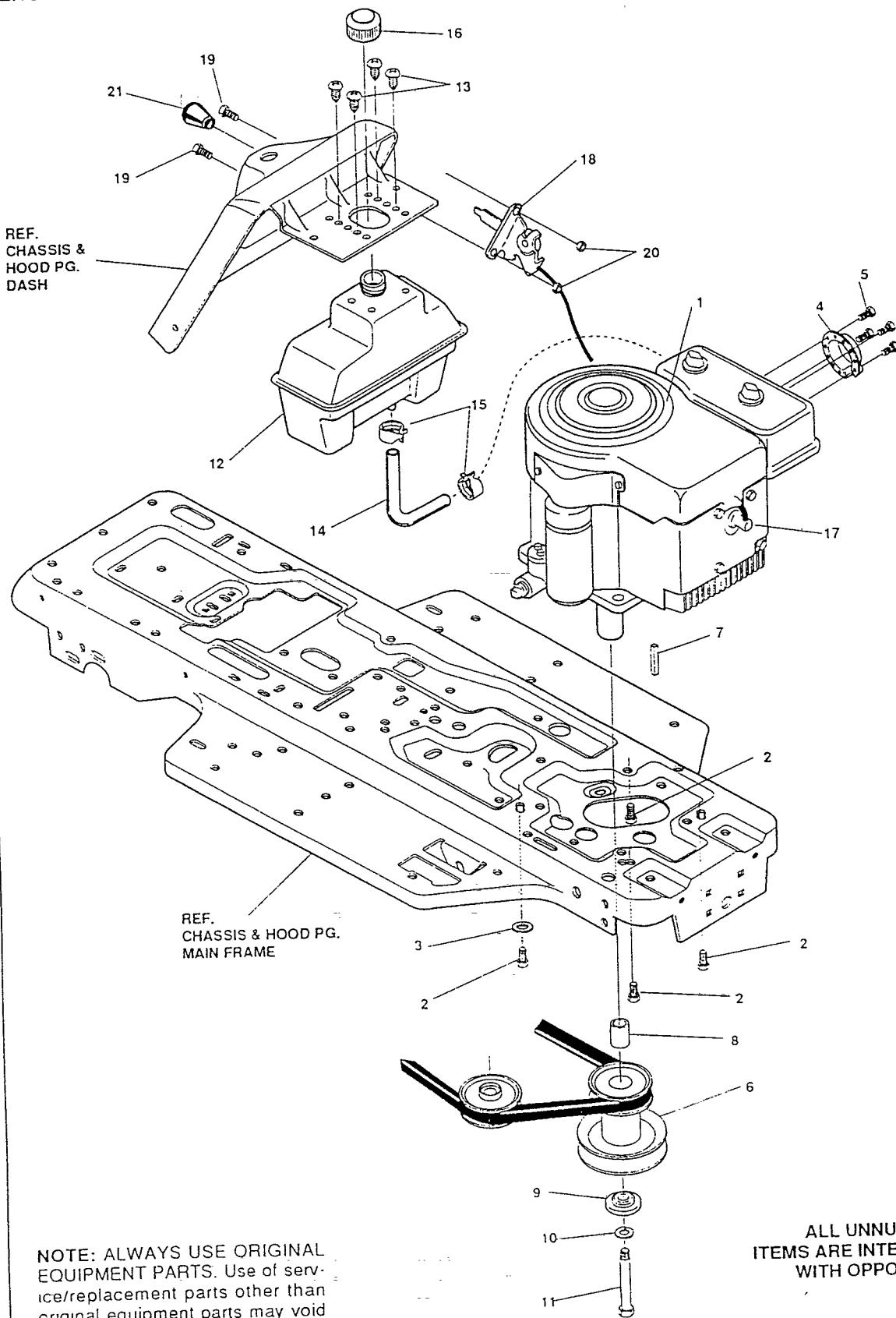

317167A

30 Texas 872
3554-240

32" LAWN TRACTOR MODEL B3554-590

key#	part#	description	qty.
1	ENGINE	SEE ENGINE MANUAL	1
2	050947	SCREW, 3/8-16X1.25 WAHTAP	4
3	0138489	WASHER, EXLK .384X.69X.04	1
4	306274	DEFLECTOR LOUVERED	1
5	035287	SCREW 8-32X.38 HHWATAP	4
6	310250	PULLEY, ENGINE	1
7	303151	KEY, SQUARE .249SQX4.50LG -	1
8	304246	SPACER	1
9	056431	WASHER, .98IDX1.38ODX.437 PILOT	1
10	0120383	WASHER, REGSPTLK.459X.78X.12 -	1
11	0433146	SCREW, 7/16-20X4.25 HHC	1
12	314989	TANK, FUEL 1 GALLON	1
13	049050	SCREW, 1/4-10X .75PHPNTAP	4
14	47452	GAS LINE .25ID BULK LENGTH	12'
15	48672	CLAMP, GAS LINE (1/2 DIA HOSE)	2
16	46704	GAS CAP	1
17	49221	RESTOR PLUG	1
18	303275	THROTTLE CONTROL	1
19	035291	SCREW, 10-24X .50 SLHHMA	2
20	0271166	NUT, #10-24 HEXKEPS	2
21	50607	KNOB,ROUND THROTTLE	1

◊ Indicates STANDARD HARDWARE ITEMS..

32" LAWN TRACTOR MODEL B3554-590

PRE-PAINTED DECK ASSEMBLY

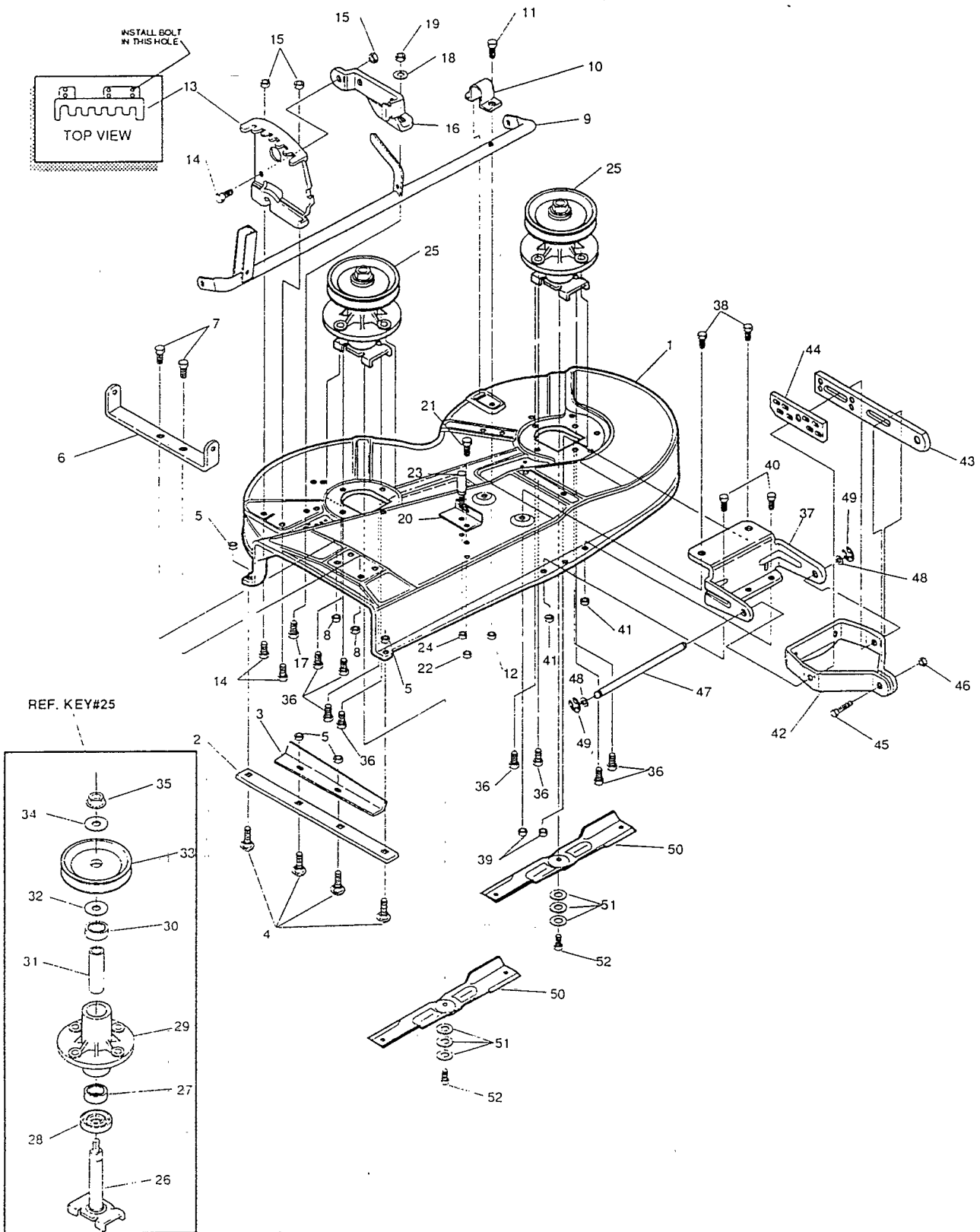

12562E

2" LAWN TRACTOR MODEL B3554-590

key#	part#	description	qty.
1	309948	32"SD DECK	1
2	55370	SKID BAR	1
3	55368	CHUTE DEFL-RIDER	1
4	126216	BOLT, 5/16-18X .75 CARR	4
5	◇ 271184	NUT, 5/16-18 HEXKEPS	4
6	57432	CHUTE PIVOT BRKT	1
7	◇ 122007	SCREW, 5/16-18X .75 HHC	2
8	◇ 1498	NUT, 5/16-18 REGHEXCTRLK	2
9	12561	ASSY.PIVOT TUBE -	1
10	51985	SUPPORT,PIVOT TUBE -	1
11	◇ 120228	SCREW, 5/16-18X .63 HHC	1
12	◇ 1498	NUT, 5/16-18 REGHEXCTRLK	1
13	12559	BRKT.HEIGHT ADJUST 312 630	1
14	◇ 120228	SCREW, 5/16-18X .63 HHC	3
15	◇ 1498	NUT, 5/16-18 REGHEXCTRLK	3
16	53781	BRACE 30"SD DECK	1
17	◇ 180120	SCREW, 3/8-16X .75 HHC	1
18	◇ 120394	WASHER, FLAT .406X .81X.065	1
19	◇ 1499	NUT, 3/8-16 REGHXCTRLK	1
20	57519	BRACKET, SWITCH	1
21	◇ 120228	SCREW, 5/16-18X .63 HHC	1
22	◇ 1498	NUT, 5/16-18 REGHEXCTRLK	1
23	40305	SHOULDER PIN	1
24	◇ 1499	NUT, 3/8-16 REGHXCTRLK	1
25	56283	QUILL, 3/42" ASSEMBLY	2
26	56623	SHAFT/SADDLE ASSY.	1
27	49562	BEARING, BALL	1
28	50616	DUST SHIELD	1
29	55547	QUILL CASTING	1
30	49562	BRNG, BALL	1
31	50818	SPACER,3.797LGX.669IDX.88OD	1
32	56280	SPACER	1
33	56391	QUILL PULLEY	1
34	56365	SPECIAL WASHER -	1
35	1282	NUT, 7/16-20 WDFLLK	1
36	50634	SCREW, 5/16-18X .88 WAHHTAP	8
37	48676	LIFT PLATE	1
38	◇ 120228	SCREW, 5/16-18X .75 HHC	2
39	◇ 1498	NUT, 5/16-18 REGHEXCTRLK	2
40	55686	SCREW, 1/4-20X .63 SLTRMA	2
41	◇ 271172	NUT, 1/4-20 REGHEXKEPS	2
42	50613	BRACKET,PIVOT	1
43	49059	BAR, HITCH	1
44	49058	BRACKET, LOCK -	1
45	◇ 120918	SCREW, 3/8-16X1.50 HHC	1
46	◇ 1499	NUT, 3/8-16 REGHXCTRLK	1
47	55724	PIN, PIVOT ROD .50DX7.55	1
48	◇ 996425	WASHER, FLAT .515X .88X.064	2
49	20864	RING, RET E .39X.04	2
50	56820	BLADE, 32" LOW-LIFT 16 8684	2
51	2483	WASHER, .39IDX1.25DX.07 BELLVIL	6
52	39573	SCREW, 3/8-24X1.00 NYLHHC	2

◇ Indicates STANDARD HARDWARE ITEMS.

32" LAWN TRACTOR MODEL B3554-590

PAINTED DECK ASSEMBLY

*12562 - DECK ASSY. PRE-PAINT

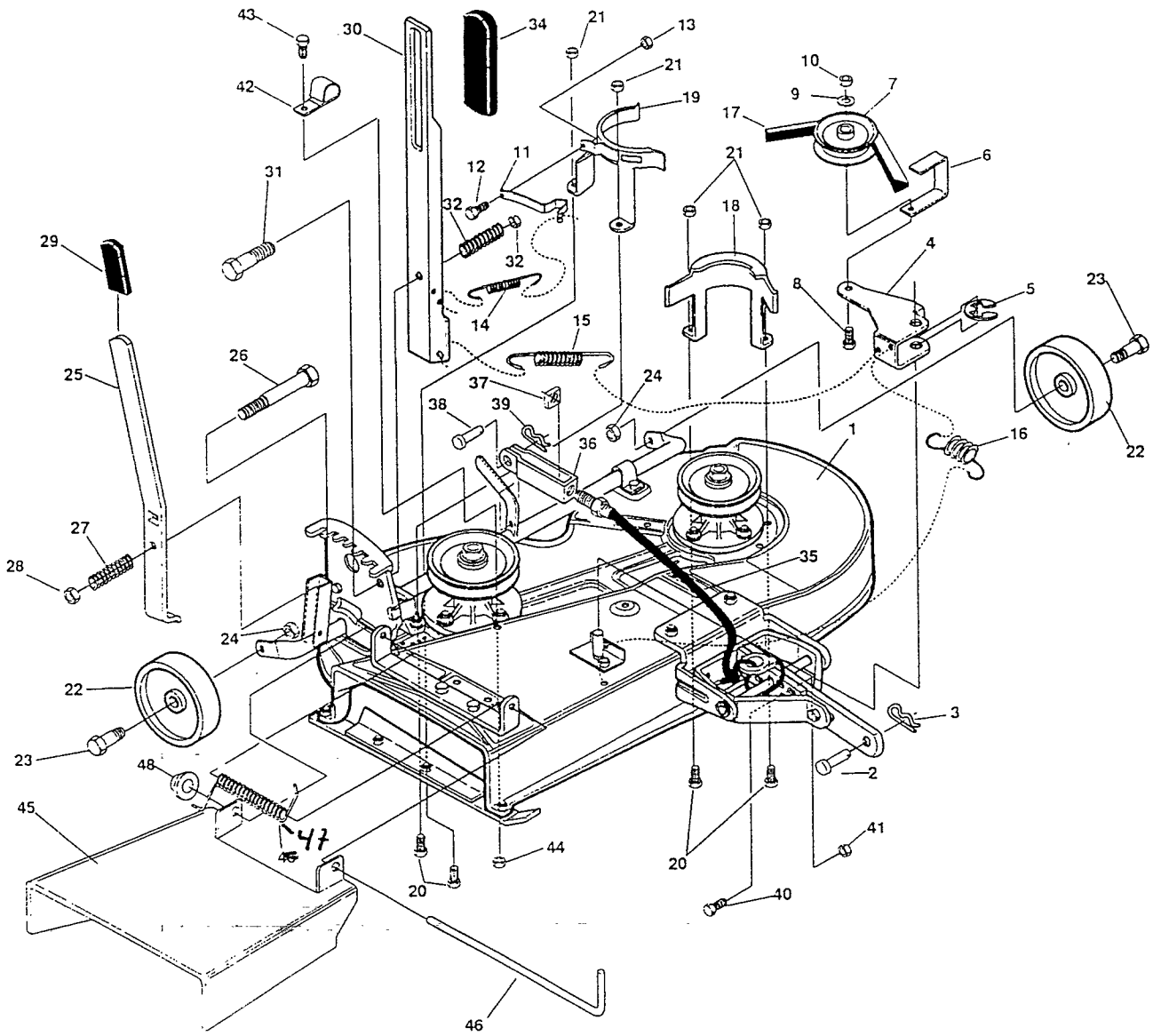

NOTE: ALWAYS USE ORIGINAL EQUIPMENT PARTS.
Use of service/replacement parts other than original equipment parts may void your warranty.

ALL UNNUMBERED
ITEMS ARE INTERCHANGABLE
WITH OPPOSITE SIDE

315925B

" LAWN TRACTOR MODEL B3554-590

key#	part#	description	qty.
1	*	32" MOWER DECK ASSEMBLY	1
2	47816	PIN, .495X1.750 CLEVIS-SHORT	1
3	56180	PIN, HAIR .091 DIA X 1.62LG	1
4	304883	BRACKET IDLER 32SD ←	1
5	20864	RING, RET E .39X.04	1
6	3382	RETAINER, STRAP BELT ←	1
7	39498	IDLER PULLEY, DRIVE	1
8	◇ 122181	SCREW, 3/8-16X2.00 HHC ←	1
9	120382	SPLIT LOCKWASHER .393 X .68 X .10 Z	1
10	◇ 120377	NUT, 3/8-16 REGHX	1
11	44992	BELT BRAKE SPRING	1
12	◇ 443874	SCREW, 10-24X .50 HHMA ←	1
13	◇ 997316	NUT, #10-24 REGHEXCTRLK	1
14	12556	SPRING, BRAKE RELEASE	1
15	12557	SPRING, DECK ENGAGE	1
16	41357	RETURN SPRING	1
17	45186	BELT, V 4L 63.00	1
18	307652	COVER QUILL L.H	1
19	307653	COVER QUILL R.H.	1
20	◇ 120228	SCREW, 5/16-18X1.00 HHC	4
21	◇ 1498	NUT, 5/16-18 REGHEXCTRLK	4
22	52584	WHEEL, SD 6.00ODX1.38WD SMO	2
23	23763	BOLT, .500X1.656 HSSH 3/8-16	2
24	◇ 1499	NUT, 3/8-16 REGHXCTRLK	2
25	8903	LEVER, HT. ADJ. ←	1
26	◇ 120696	SCREW, 5/16-18X2.25 HHC ←	1
27	53246	SPRING ←	1
28	◇ 1498	NUT, 5/16-18 REGHEXCTRLK	1
29	53995	GRIP HANDLE ←	1
30	9126	HANDLE, DECK ENGAGE BLK ←	1
31	◇ 122040	SCREW, 5/16-18X1.50 HHC	1
32	29170	SPRING ←	1
33	◇ 1498	NUT, 5/16-18 REGHEXCTRLK	1
34	55213	GRIP ←	1
35	57511	LIFT CABLE	1
36	9405	CLEVIS, LIFT CABLE	1
37	◇ 120372	NUT, 1/4-20 REGSQ	1
38	39522	PIN CLEVIS .312 X .812	1
39	56180	PIN, HAIR .091 DIA X 1.62LG	1
40	◇ 120228	SCREW, 5/16-18X .63 HHC	1
41	◇ 1498	NUT, 5/16-18 REGHEXCTRLK	1
42	57569	RETAINER, .311DX.62X.03 WIRE	1
43	◇ 120228	SCREW, 5/16-18X .63 HHC	1
44	◇ 1498	NUT, 5/16-18 REGHEXCTRLK	1
45	8905	CHUTE, DISCHARGE	1
46	57430	DEFLECTOR CHUTE PIVOT ROD ←	1
47	57431	SPRING TORSION CHUTE DEF	1
48	57507	PUSH NUT ←	1

* Order Individual Parts.

◇ Indicates STANDARD HARDWARE ITEMS.

32" LAWN TRACTOR MODEL B3554-590

ELECTRICAL ASSEMBLY

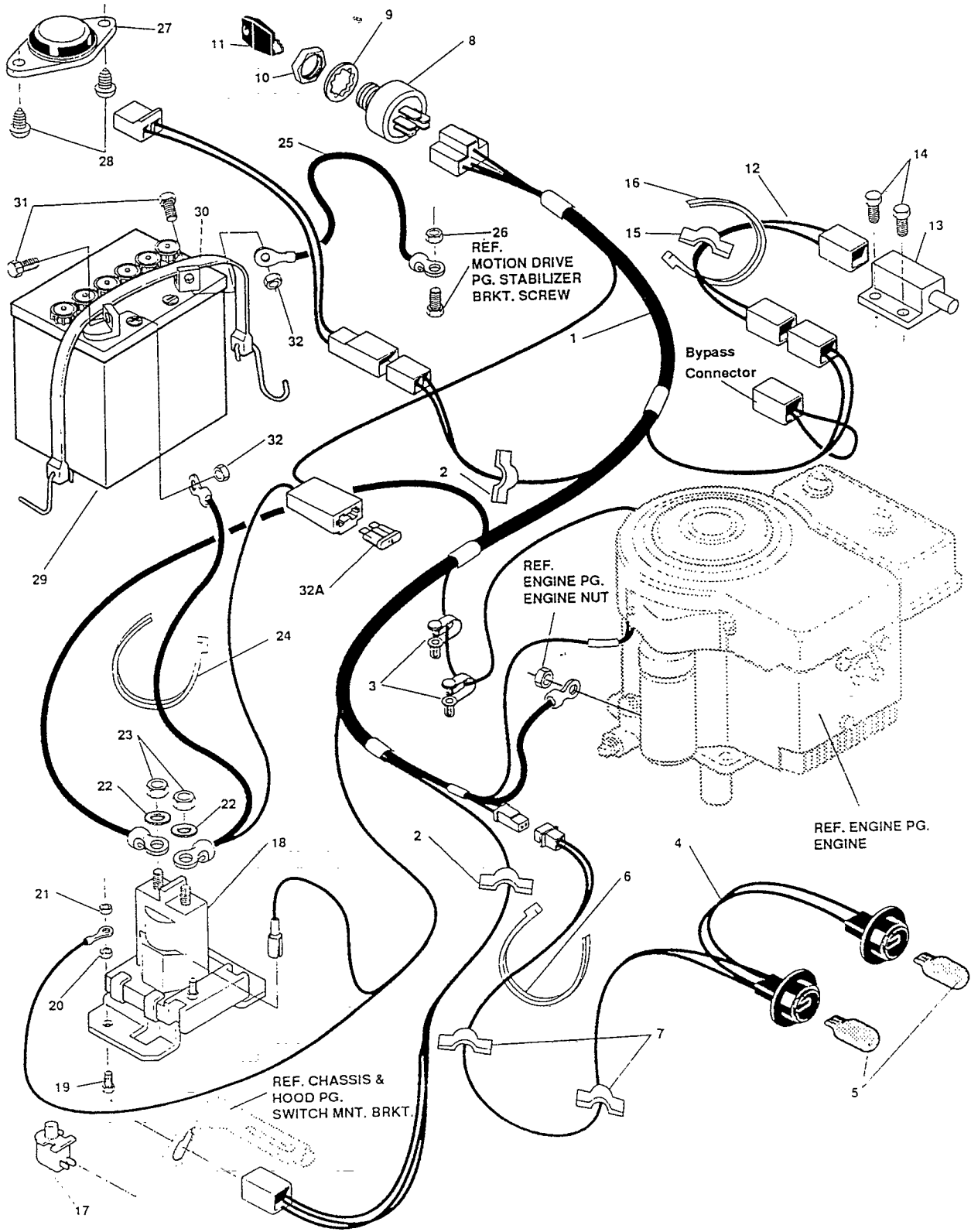

NOTE: ALWAYS USE ORIGINAL EQUIPMENT PARTS.
Use of service/replacement parts other than original equipment parts may void your warranty.

**ALL UNNUMBERED
ITEMS ARE INTERCHANGABLE
WITH OPPOSITE SIDE**

315948A

AWN TRACTOR MODEL B3554-590

key#	part#	description	qty.
1	57642	WIRE HARNESS	1
2	41482	CLIP, PRESS WIRE	2
3	54888	RETAINER, WIRE	2
4	303064	ASSY., LIGHT WIRE	1
5	52572	BULB, HEADLAMP	2
6	57444	TIE, CABLE	1
7	41482	CLIP, PRESS WIRE	2
8	300687	SWITCH, IGNITION & LIGHTS	1
9	0138557	WASHER, REGINTLK	1
10	48140	NUT, 5/8-32 HXHD IGN SWIT	1
11	300626	KEY, IGNITION SWITCH	1
12	57564	HARNESS, DECK WIRE	1
13	57476	SWITCH	1
14	057220	SCREW, #12 X .50 PHPNHTAP	2
15	041482	CLIP, PRESS WIRE	1
16	57444	TIE, CABLE BLACK NYLON	1
17	300220	SWITCH, SNAPMNT NO .055/.116	1
18	53716	SOLENOID, NEW CLUM	1
19	0187745	SCREW, 1/4-20 X .75 HXSEMMA	2
20	01502	NUT, 1/4-20 REGHEXCTRLK	2
21	0271172	NUT, 1/4-20 HEXKEPS	1
22	0138485	WASHER, EXLK .320 X .61 X .03	2
23	0120368	NUT, 5/16-24 REGHEX	2
24	57444	TIE, CABLE	1
25	55511	WIRE, GROUND	1
26	0271184	NUT, 5/16 - 18 HEXKEPS	1
27	57547	SWITCH, SEAT	1
28	0160505	SCREW, 1/4-20 PNPNHM	2
29	57486	BATTERY, 12V 5 PLATE 52906	1
30	309862	STRAP, RUBBER	1
31	0120854	SCREW, 1/4-20 X .63 HHC	2
32	0271172	NUT, 1/4-20 H KEPS	2
33A	**302031	FUSE, 15 AMP SHADE TYPE	1
33B	**49211	FUSE, 15 AMP CYLINDRICAL TYPE	1

◇ Indicates STANDARD HARDWARE ITEMS.

**Cylindrical or Spade type fuses are included with the wire harness.

32" LAWN TRACTOR MODEL B3554-590

DECALS

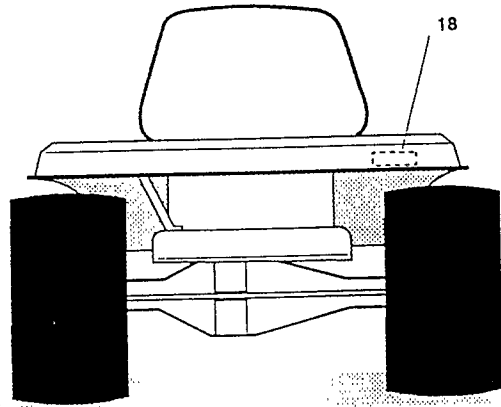
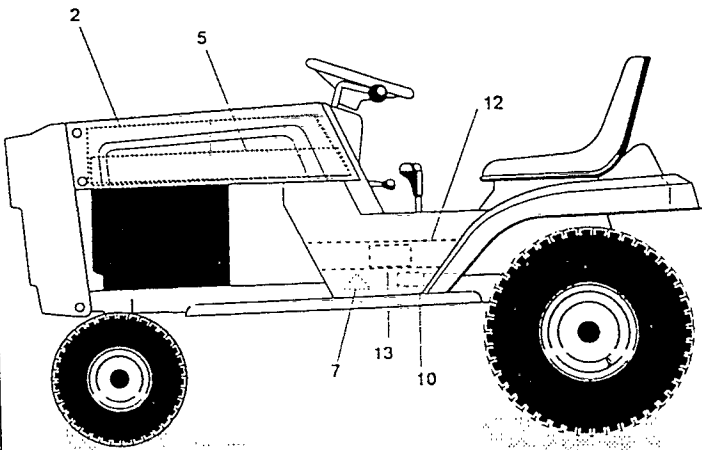
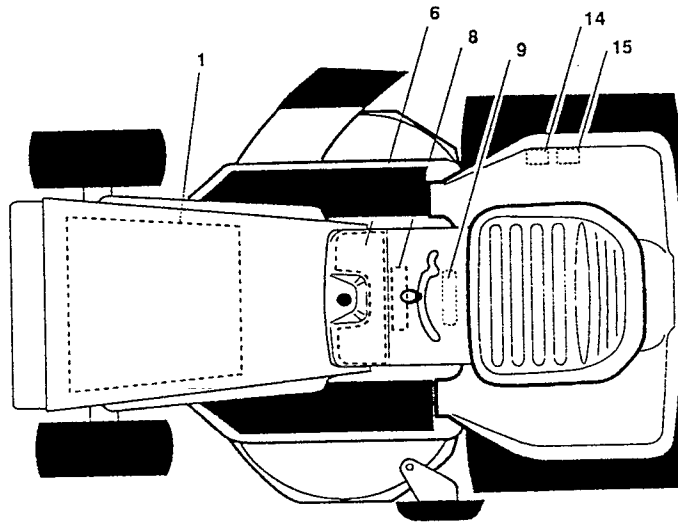
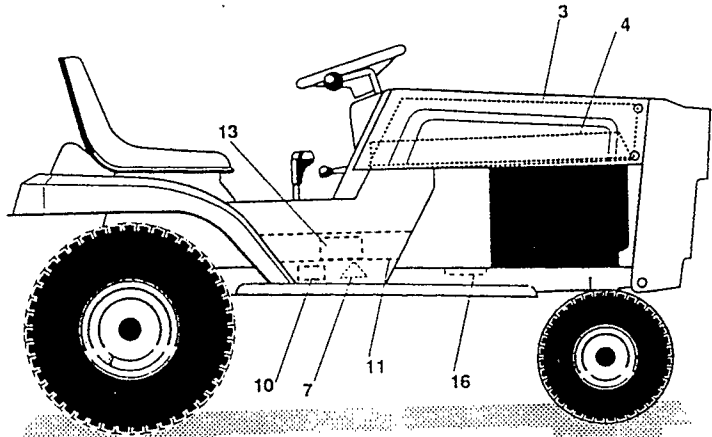
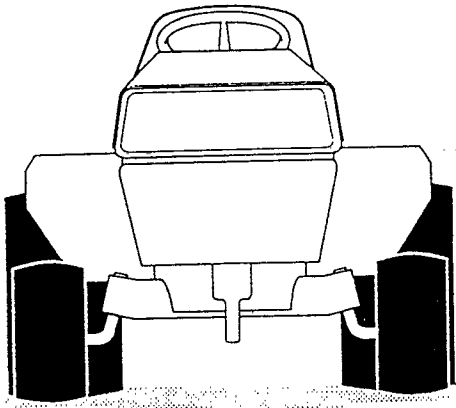

NOTE: ALWAYS USE ORIGINAL EQUIPMENT PARTS.
Use of service/replacement parts other than original equipment parts may void your warranty.

ALL UNNUMBERED
ITEMS ARE INTERCHANGABLE
WITH OPPOSITE SIDE

317229A

2" LAWN TRACTOR MODEL B3554-590

key#	part#	description	qty
1	55832	PAD FOAM TOP HOOD	1
2	55833	PAD FOAM LH SIDE HOOD	1
3	55834	PAD FOAM RH SIDE HOOD	1
4	314456	DECAL, HOODSIDE RH	1
5	314457	DECAL, HOODSIDE LH	1
6	307412	DECAL,DASH PLAIN SF DYN EUROPE	1
7	305770	DECAL,CAUTION TRIANGLE EUROPE	2
8	307047	DECAL,3-SPEED CONSOLE TOP	1
9	307376	DECAL,INSTRUCTION CONS DANISH	1
10	307377	DECAL,WARNING DANISH	2
11	314460	DECAL, CONSOLE RH STRETCH FRM	1
12	314461	DECAL, CONSOLE LH STRETCH FRM	1
13	300556	NAME PLATE,8/32 WHITE	2
14	68900	DECAL,BLADE ENGAGE EUROPE	1
15	68901	DECAL,BLADE HEIGHT ADJ. EUROPE	1
16	68903	DECAL,BRAKE/CLUTCH EUROPE	1
17		REFERENCE ONLY	1
18	302886	NAMEPLATE SM. DYNA	1
19		REFERENCE ONLY	1

32" LAWN TRACTOR MODEL B3554-590

CUSTOMER ASSEMBLY

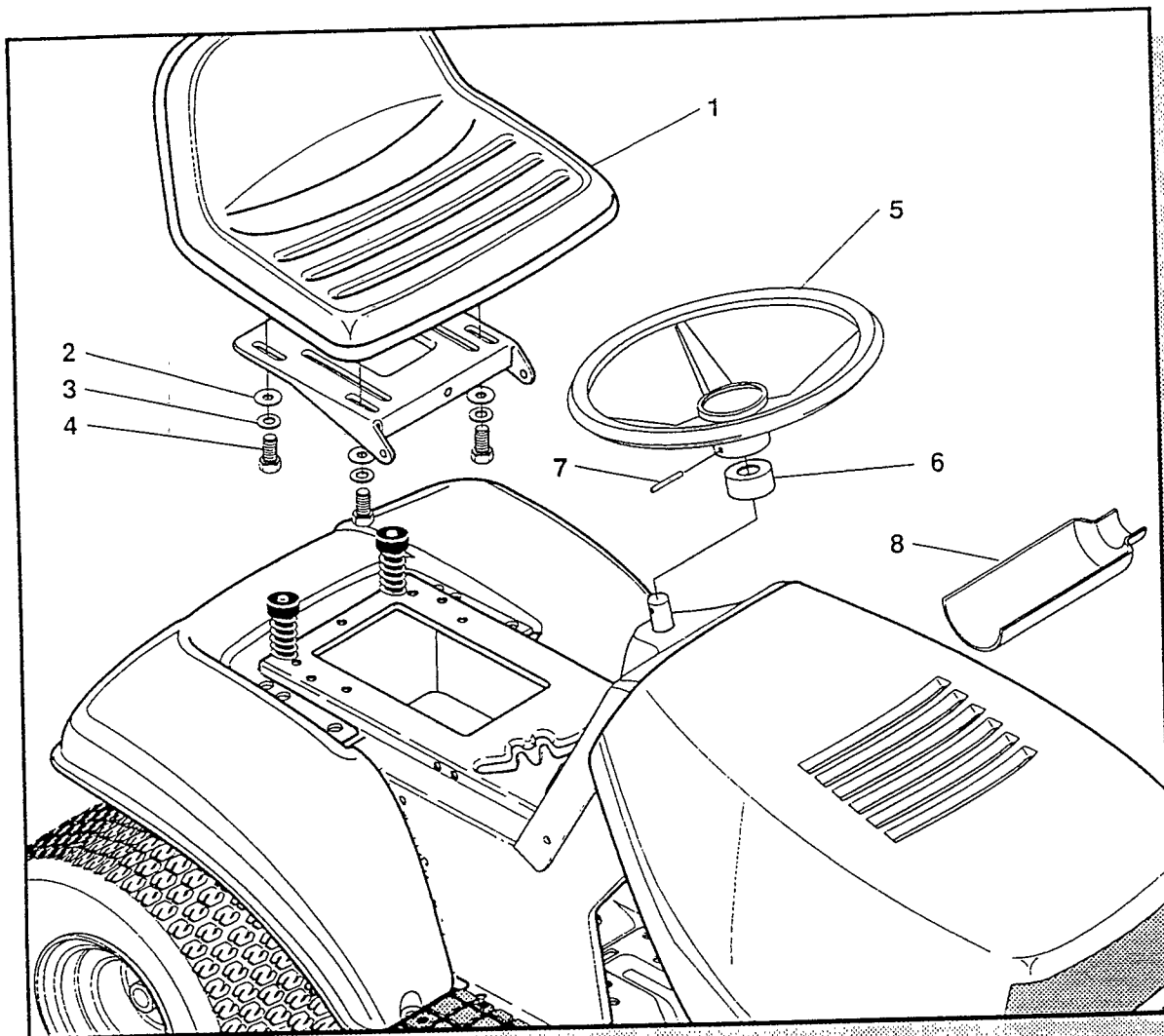

CUSTOMER ASSEMBLY VIEW

315134 PARTS BAG ASSY QTY1

key#	part#	decription	qty
1	57452	SEAT MV350	1
2	120393	WASHER,FLAT .344X.69X.065	4
3	120638	WASHER, HVSPLTLK .328X.60X.109	4
4	122007	SCREW, 5/16-18X.75 HHC	4
5	301251	STEERING WHEEL	1
6	314775	STEERING, SLEEVE	1
7	456378	ROLL PIN .250DIAX2.0LG	1
8	54873	OIL TROUGH	1

316235

TREAD PATTERNS

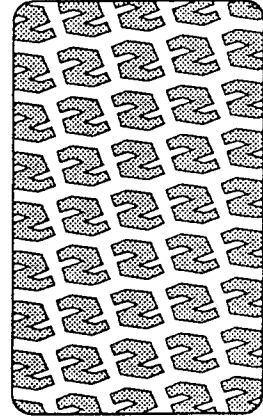
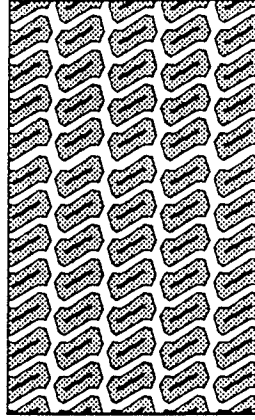
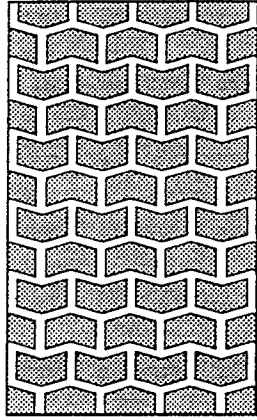
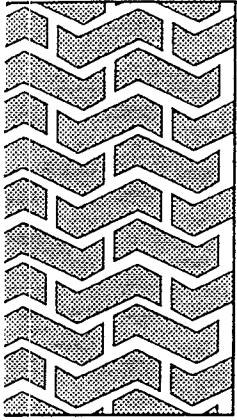

TIRE SIZE	"A"	"B"	"C"	"D"
11 X 4.00 - 5	42295			
13 X 5.00 - 6	41060			
15 X 6.00 - 6	301140	316702	39830	313952
16 X 6.50 - 8		41081		314539
18 X 6.50 - 8				
18 X 9.50 - 8		316701		313950
20 X 8.00 - 8	314584			
20 X 10.00 - 8	58276			313565
20 X 10.00 - 10		55893		
23 X 9.50 - 12	314370			
23 X 9.50 - 12		53655		